

SERVICE MANUAL

BA-5 CHASSIS

Self Diagnosis
Supported model

<u>MODEL</u>	<u>COMMANDER</u>	<u>DEST</u>	<u>CHASSIS NO.</u>
KV-27FS12	RM-Y168	US	SCC-S40D-A
KV-27FS12	RM-Y168	CND	SCC-S41D-A
KV-27FS16	RM-Y169	US	SCC-S40E-A
KV-29FS12	RM-Y168	E	SCC-S38K-A
KV-29FS12C	RM-Y168	E	SCC-S38L-A



KV-27FS16



RM-Y168

TRINITRON® COLOR TV
SONY®

SPECIFICATIONS

	KV-27FS12	KV-27FS16	KV-29FS12	KV-29FS12C
Power requirements	120V, 60Hz	120V, 60Hz	120V/220V, 60Hz/50Hz	120V/220V, 60Hz/50Hz
Number of inputs/outputs				
Video ¹⁾	3	3	3	3
S Video ²⁾	1	1	1	1
Audio ³⁾	3	3	3	3
Audio Out ⁴⁾	1	1	1	1
Y, P _B , P _R ⁵⁾	1	1	1	1
Speaker output(W)	5Wx2	5Wx2	10Wx2	10Wx2
Power Consumption(W)				
In use(Max)	160W	170W	185W	185W
In standby	1W	1W	1W	1W
Dimensions(W/H/D)				
(mm)	700 x 632 x 512 mm.	700 x 632 x 512 mm.	700 x 632 x 512 mm.	700 x 632 x 512 mm.
(in)	27 ^{1/2} x 24 ^{7/8} x 20 ^{1/8} in.	27 ^{1/2} x 24 ^{7/8} x 20 ^{1/8} in.	27 ^{1/2} x 24 ^{7/8} x 20 ^{1/8} in.	27 ^{1/2} x 24 ^{7/8} x 20 ^{1/8} in.
Mass				
(kg)	47kg	47kg	47kg	47kg
(lbs)	103 lbs. 10 oz.	103 lbs. 10 oz.	103 lbs. 10 oz.	103 lbs. 10 oz.

- 1) 1 Vp-p 75 ohms unbalanced, sync negative
- 2) Y: 1 Vp-p 75 ohms unbalanced, sync negative
C: 0.286 Vp-p (Burst signal), 75 ohms
- 3) 500mVrms (100% modulation), impedance: 47kilohms
- 4) More than 408 mVrms at the maximum volume setting (variable)
More than 408 mVrms (fix)
- 5) Y: 1.0 Vp-p, 75 ohms, sync negative; P_B: 0.7 Vp-p, 75 ohms;
P_R: Vp-p, 75 ohms

Television system

American TV standard/NTSC

Channel coverage

VHF:2-13/UHF:14-69/CATV:1-125

Visible screen size

27" picture measured diagonally

Actual screen size

29" picture measured diagonally

Antenna

75 ohm external antenna terminal for VHF/UHF

Supplied accessories

Remote Commander RM-Y168 (ALL EXCEPT KV-27FS16)
Remote Commander RM-Y169 (KV-27FS16 ONLY)
Size AA (R6) batteries (2)

Optional accessories

Connecting cables: VMC-810S/820S, VMC-720M,
YC-15V/30V, RK74A
U/V mixer EAC-66
TV Stand: SU27FD3

Design and specifications are subject to change without notice.

TABLE OF CONTENTS

<i>Section</i>	<i>Title</i>	<i>Page</i>
	Warnings and Cautions	4
	Self-Diagnostic Function	4
	Safety Check-Out Instructions	7
1.	GENERAL	8
2.	DISASSEMBLY	
2-1.	Rear Cover Removal	14
2-2.	Chassis Assembly Removal	14
2-3.	Service Position	14
2-4.	Picture Tube Removal	15
3.	SET-UP ADJUSTMENTS	
3-1.	Beam Landing	16
3-2.	Convergence	17
3-3.	Focus	18
3-4.	Screen (G2)	19
3-5.	Method of Setting the Service Adjustment Mode	19
3-6.	White Balance Adjustments	19
4.	SAFETY RELATED ADJUSTMENTS	
4-1.	☒ R564 Confirmation Method (HV Hold-Down Confirmation and Readjustments)	20
4-2.	B+ Voltage Confirmation and Adjustment	20
5.	CIRCUIT ADJUSTMENTS	
5-1.	Setting the Service Adjustment Mode	22
5-2.	Memory Write Confirmation Method	22
5-3.	Adjustment Buttons and Indicators	22
5-4.	MA Board Adjustments	25
6.	DIAGRAMS	
6-1.	Block Diagram	31
6-2.	Circuit Board Location	35
6-3.	Printed Wiring Boards and Schematic Diagrams	35
	• A Board	36
	• MA Board	43
	• CA Board	49
	• HX Board	50
	• D Board	51
	• K Board	53
	• VA Board	54
	• P Board	55
6-4.	Semiconductors	57
7.	EXPLODED VIEW	
7-1.	Chassis (KV-27FS16/27FS12 ONLY)	58
7-2.	Chassis (KV-29FS12/29FS12C ONLY)	59
8.	ELECTRICAL PARTS LIST	60

WARNINGS AND CAUTIONS

CAUTION

SHORT CIRCUIT THE ANODE OF THE PICTURE TUBE AND THE ANODE CAP TO THE METAL CHASSIS, CRT SHIELD, OR CARBON PAINTED ON THE CRT, AFTER REMOVING THE ANODE.

WARNING!!

AN ISOLATION TRANSFORMER SHOULD BE USED DURING ANY SERVICE TO AVOID POSSIBLE SHOCK HAZARD, BECAUSE OF LIVE CHASSIS. THE CHASSIS OF THIS RECEIVER IS DIRECTLY CONNECTED TO THE AC POWER LINE.

SAFETY-RELATED COMPONENT WARNING!!

COMPONENTS IDENTIFIED BY SHADING AND MARK \triangle ON THE SCHEMATIC DIAGRAMS, EXPLODED VIEWS, AND IN THE PARTS LIST ARE CRITICAL FOR SAFE OPERATION. REPLACE THESE COMPONENTS WITH SONY PARTS WHOSE PART NUMBERS APPEAR AS SHOWN IN THIS MANUAL OR IN SUPPLEMENTS PUBLISHED BY SONY. CIRCUIT ADJUSTMENTS THAT ARE CRITICAL FOR SAFE OPERATION ARE IDENTIFIED IN THIS MANUAL. FOLLOW THESE PROCEDURES WHENEVER CRITICAL COMPONENTS ARE REPLACED OR IMPROPER OPERATION IS SUSPECTED.

ATTENTION!!

APRES AVOIR DECONNECTE LE CAP DE L'ANODE, COURT-CIRCUITER L'ANODE DU TUBE CATHODIQUE ET CELUI DE L'ANODE DU CAP AU CHASSIS METALLIQUE DE L'APPAREIL, OU AU COUCHE DE CARBONE PEINTE SUR LE TUBE CATHODIQUE OU AU BLINDAGE DU TUBE CATHODIQUE.

ATTENTION!!

AFIN D'EVITER TOUT RESQUE D'ELECTROCUTION PROVENANT D'UN CHÂSSIS SOUS TENSION, UN TRANSFORMATEUR D'ISOLEMENT DOIT ETRE UTILISÉ LORS DE TOUT DÉPANNAGE. LE CHÂSSIS DE CE RÉCEPTEUR EST DIRECTEMENT RACCORDÉ À L'ALIMENTATION SECTEUR.

ATTENTION AUX COMPOSANTS RELATIFS A LA SECURITE!!

LES COMPOSANTS IDENTIFIES PAR UNE TRAME ET PAR UNE MARQUE \triangle SUR LES SCHEMAS DE PRINCIPE, LES VUES EXPLOSEES ET LES LISTES DE PIECES SONT D'UNE IMPORTANCE CRITIQUE POUR LA SECURITE DU FONCTIONNEMENT. NE LES REMPLACER QUE PAR DES COMPOSANTS SONY DONT LE NUMERO DE PIECE EST INDIQUE DANS LE PRESENT MANUEL OU DANS DES SUPPLEMENTS PUBLIES PAR SONY. LES REGLAGES DE CIRCUIT DONT L'IMPORTANCE EST CRITIQUE POUR LA SECURITE DU FONCTIONNEMENT SONT IDENTIFIES DANS LE PRESENT MANUEL. SUIVRE CES PROCEDURES LORS DE CHAQUE REMPLACEMENT DE COMPOSANTS CRITIQUES, OU LORSQU'UN MAUVAIS FONCTIONNEMENT SUSPECTE.

SELF-DIAGNOSTIC FUNCTION

The units in this manual contain a self-diagnostic function. If an error occurs, the STANDBY/TIMER LED will automatically begin to flash. The number of times the LED flashes translates to a probable source of the problem. A definition of the STANDBY/TIMER LED flash indicators is listed in the instruction manual for the user's knowledge and reference. If an error symptom cannot be reproduced, the Remote Commander can be used to review the failure occurrence data stored in memory to reveal past problems and how often these problems occur.

Diagnostic Test Indicators

When an error occurs, the STANDBY/TIMER LED will flash a set number of times to indicate the possible cause of the problem. If there is more than one error, the LED will identify the first of the problem areas.

Results for all of the following diagnostic items are displayed on screen. No error has occurred if the screen displays a "0".

Diagnostic Item Description	No. of Times STANDBY/TIMER LED Flashes	Self-Diagnostic Display/ Diagnostic Result	Probable Cause Location	Detected Symptoms
Power does not turn on	Does not light	—————	<ul style="list-style-type: none"> • Power cord is not plugged in. • Fuse is burned out. (F601) (A Board) 	<ul style="list-style-type: none"> • Power does not come on. • No power is supplied to the TV. • AC power supply is faulty.
+B overcurrent (OCP)*	2 times	2:0 or 2:1	<ul style="list-style-type: none"> • H.OUT (Q502) is shorted. (A Board) • IC702 is shorted. (CA Board) 	<ul style="list-style-type: none"> • Power does not come on. • Load on power line is shorted.
I-Prot	4 times	4:0 or 4:1	<ul style="list-style-type: none"> • +13V is not supplied. (A Board) • IC502 is faulty. (A Board) 	<ul style="list-style-type: none"> • Has entered standby state after horizontal raster. • Vertical deflection pulse is stopped. • Power line is shorted or power supply is stopped.
IK	5 times	5:0 or 5:1	<ul style="list-style-type: none"> • Video OUT (IC502) is faulty. (A Board) • IC301 is faulty. (MA Board) • Screen (G2) is improperly adjusted.** 	<ul style="list-style-type: none"> • No raster is generated. • CRT cathode current detection reference pulse output is small.

* If a +B overcurrent is detected, stoppage of the vertical deflection is detected simultaneously. The symptom that is diagnosed first by the microcontroller is displayed on the screen.

** Refer to Screen (G2) Adjustments in Section 3-4 of this manual.

Display of Standby/Timer LED Flash Count

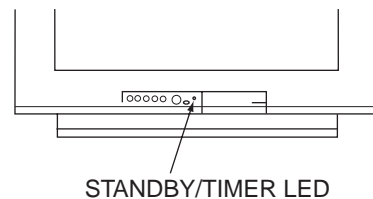
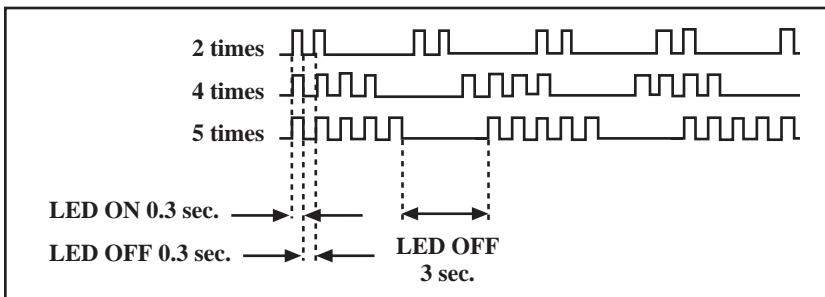

<u>Diagnostic Item</u>	<u>Flash Count*</u>
+B overcurrent	2 times
I-Prot	4 times
IK	5 times

*One flash count is not used for self-diagnostic.

Stopping the Standby/Timer LED Flash

Turn off the power switch on the TV main unit or unplug the power cord from the outlet to stop the STANDBY/TIMER LAMP from flashing.

Self-Diagnostic Screen Display

For errors with symptoms such as “power sometimes shuts off” or “screen sometimes goes out” that cannot be confirmed, it is possible to bring up past occurrences of failure on the screen for confirmation.

To Bring Up Screen Test

In standby mode, press buttons on the Remote Commander sequentially, in rapid succession, as shown below:

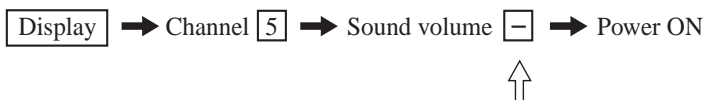

↑
Note that this differs from entering the service mode (sound volume [+]).

Self-Diagnostic Screen Display

SELF DIAGNOSTIC			
2:		0	← Numeral “0” means that no fault was detected.
3:	N/A	0	
4:		0	
5:		1	← Numeral “1” means a fault was detected one time only.
101:	N/A	0	

Handling of Self-Diagnostic Screen Display

Since the diagnostic results displayed on the screen are not automatically cleared, always check the self-diagnostic screen during repairs. When you have completed the repairs, clear the result display to "0".

Unless the result display is cleared to "0", the self-diagnostic function will not be able to detect subsequent faults after completion of the repairs.

Clearing the Result Display

To clear the result display to "0", press buttons on the Remote Commander sequentially when the diagnostic screen is displayed, as shown below:

Channel **8** → **ENTER**

Quitting the Self-Diagnostic Screen

To quit the entire self-diagnostic screen, turn off the power switch on the Remote Commander or the main unit.

Self-Diagnostic Circuit

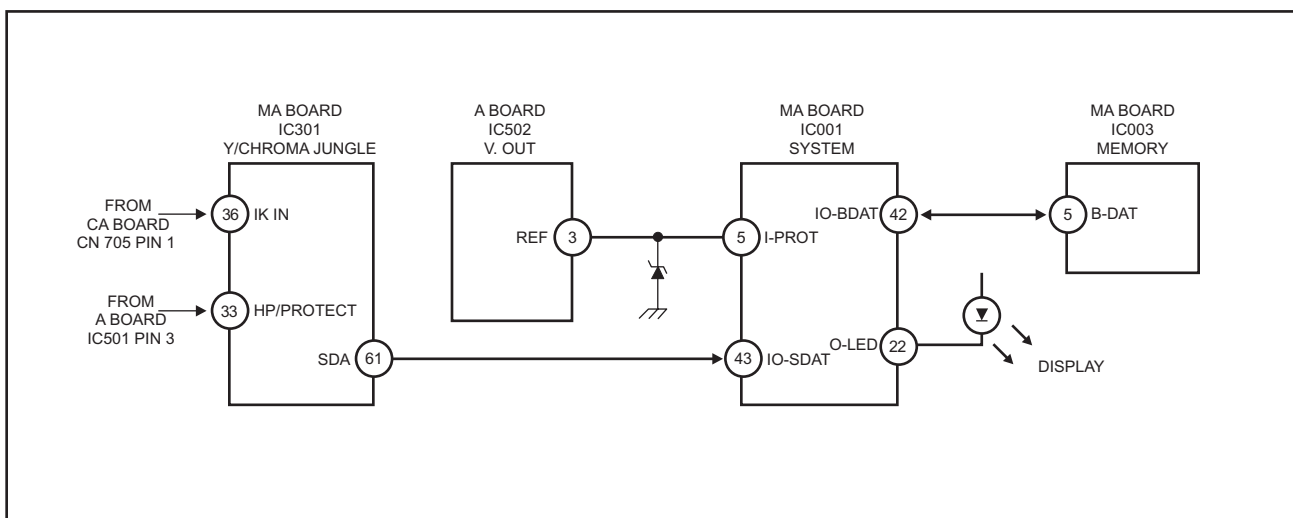

+B overcurrent (OCP)

Occurs when an overcurrent on the +B (135V) line is detected by pin 33 of IC301 (MA Board). If the voltage of pin 33 of IC301 (MA Board) is less than 1V when V.SYNC is more than seven verticals in a period, the unit will automatically turn off.

I-Prot

Occurs when an absence of the vertical deflection pulse is detected by pin 5 of IC001 (MA Board). Power supply will shut down when waveform interval exceeds 2 seconds.

IK

If the RGB levels* do not balance within 2 seconds after the power is turned on, this error will be detected by IC301 (MA Board). TV will stay on, but there will be no picture.

*(Refers to the RGB levels of the AKB detection Ref pulse that detects 1K).

SAFETY CHECK-OUT

After correcting the original service problem, perform the following safety checks before releasing the set to the customer:

1. Check the area of your repair for unsoldered or poorly soldered connections. Check the entire board surface for solder splashes and bridges.
2. Check the interboard wiring to ensure that no wires are "pinched" or touching high-wattage resistors.
3. Check that all control knobs, shields, covers, ground straps, and mounting hardware have been replaced. Be absolutely certain that you have replaced all the insulators.
4. Look for unauthorized replacement parts, particularly transistors, that were installed during a previous repair. Point them out to the customer and recommend their replacement.
5. Look for parts which, though functioning, show obvious signs of deterioration. Point them out to the customer and recommend their replacement.
6. Check the line cords for cracks and abrasion. Recommend the replacement of any such line cord to the customer.
7. Check the B+ and HV to see if they are specified values. Make sure your instruments are accurate; be suspicious of your HV meter if sets always have low HV.
8. Check the antenna terminals, metal trim, "metallized" knobs, screws, and all other exposed metal parts for AC leakage. Check leakage as described below.

Leakage Test

The AC leakage from any exposed metal part to earth ground and from all exposed metal parts to any exposed metal part having a return to chassis, must not exceed 0.5 mA (500 microamperes). Leakage current can be measured by any one of three methods.

1. A commercial leakage tester, such as the Simpson 229 or RCA WT-540A. Follow the manufacturers' instructions to use these instruments.
2. A battery-operated AC milliammeter. The Data Precision 245 digital multimeter is suitable for this job.
3. Measuring the voltage drop across a resistor by means of a VOM or battery-operated AC voltmeter. The "limit" indication is 0.75 V, so analog meters must have an accurate low voltage scale. The Simpson's 250 and Sanwa SH-63TRD are examples of passive VOMs that are suitable. Nearly all battery-operated digital multimeters that have a 2 VAC range are suitable (see Figure A).

How to Find a Good Earth Ground

A cold-water pipe is a guaranteed earth ground; the cover-plate retaining screw on most AC outlet boxes is also at earth ground. If the retaining screw is to be used as your earth ground, verify that it is at ground by measuring the resistance between it and a cold-water pipe with an ohmmeter. The reading should be zero ohms. If a cold-water pipe is not accessible, connect a 60- to 100-watt trouble-light (not a neon lamp) between the hot side of the receptacle and the retaining screw. Try both slots, if necessary, to locate the hot side on the line; the lamp should light at normal brilliance if the screw is at ground potential (see Figure B).

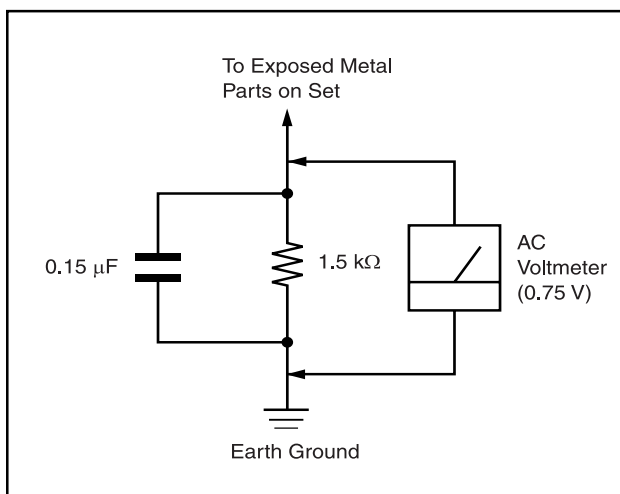

Figure A. Using an AC voltmeter to check AC leakage.

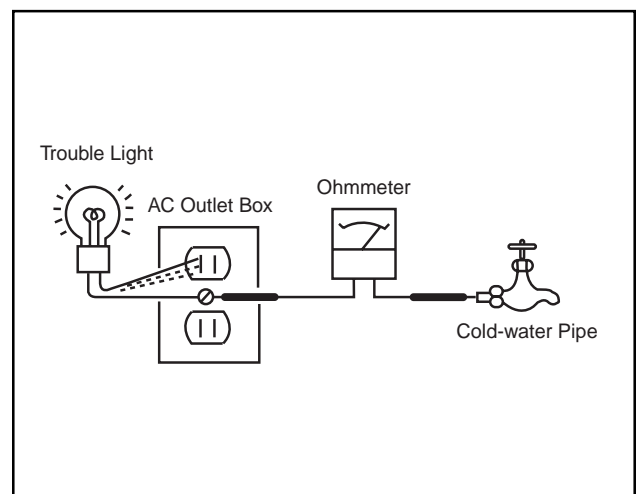

Figure B. Checking for earth ground.

SECTION 1 GENERAL

The instructions mentioned here are partial abstracts from the Operating Instruction Manual. The page numbers shown reflect those of the Operating Instruction Manual.

Connecting Your TV

Read this chapter before setting up your TV for the first time. This section covers basic connections in addition to any optional equipment you may be connecting.

Basic Connections

TV with indoor or outdoor antenna, or CATV cable

Depending on the cable available in your home, choose one of the connections below:

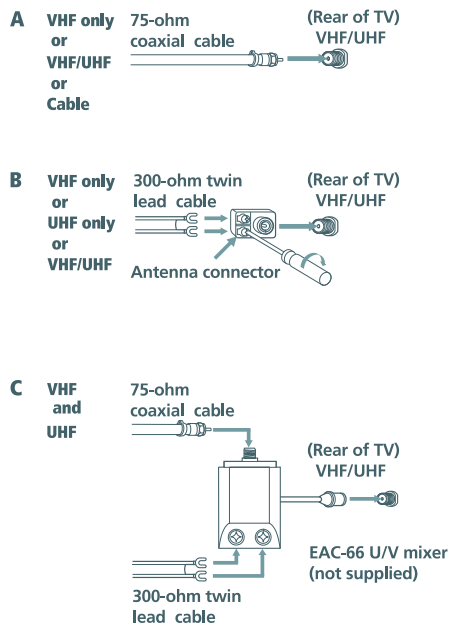

If you are connecting to an indoor or outdoor antenna, you may need to adjust the orientation of the antenna for best reception.

3

Operating Instructions

Cable Box Connections

Some pay cable TV systems use scrambled or encoded signals that require a cable box to view all channels.

Cable Box

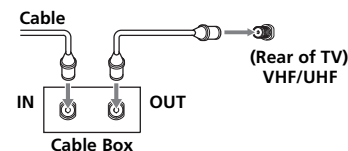

- 1 Connect the coaxial cable from your cable service to the IN jack on your cable box.
- 2 Connect a coaxial cable (not supplied) from the OUT jack on your cable box to the VHF/UHF jack on your TV.

If you will be controlling all channel selection through your cable box, you should consider using the Channel Fix feature, (see page 26).

Cable Box and Cable

For this set up, you can switch between scramble channels (through your cable box), and normal (CATV) channels by using the **ANT** button.

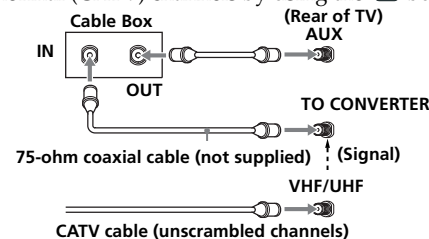

If you are connecting a cable box through the AUX input and would like to switch between the AUX and normal (CATV) input, you should consider using the Channel Fix feature, (see page 26).

Your Sony remote control can be programmed to operate your cable box, (see page 36).

When using PIP, you cannot view the AUX input in the window picture.

4

Connecting Additional Equipment

TV and VCR

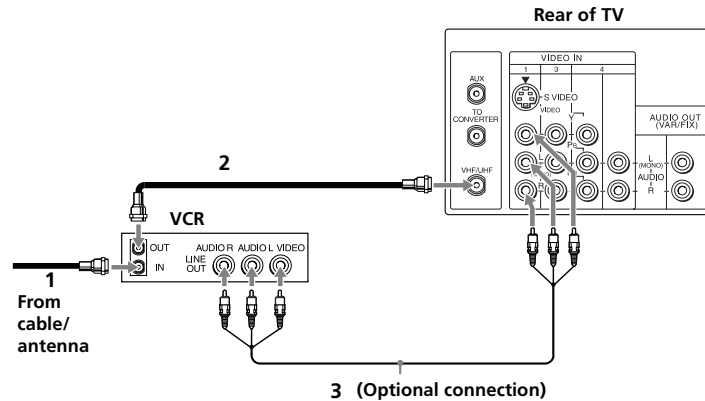

- 1** Connect the coaxial cable from your TV antenna or cable service to the IN jack on your VCR.
- 2** Connect a coaxial cable (not supplied) from the OUT jack on your VCR to the VHF/UHF jack on the TV.

To watch video programs from your VCR, tune your TV to channel 3 or 4 (as set on the rear of your VCR).

(Optional connection)

- 3** If your VCR is equipped with video outputs, you can get better picture quality by connecting A/V cables (not supplied) from AUDIO and VIDEO OUT on your VCR to AUDIO/VIDEO IN on your TV.

For optimum picture quality, use S VIDEO instead of the yellow AV cable. S VIDEO does not provide sound, the audio cables must still be connected.

You can use the button to switch between the VHF/UHF and VIDEO inputs.

TV and Cable Box

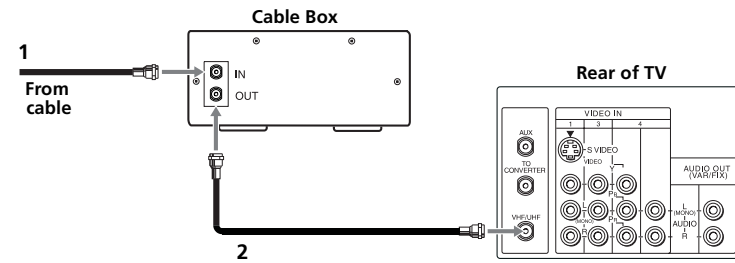

- 1** Connect the coaxial cable from your cable service to the IN jack on your cable box.
- 2** Connect a coaxial cable (not supplied) from the OUT jack on your cable box to the VHF/UHF jack on the TV.

To view channels from your cable box, tune your TV to channel 3 or 4 (as set on the rear panel of your cable box) and use the cable box's remote control to change channels.

If you will be controlling all channel selection through your cable box, you should consider using the Channel Fix feature, (see page 26).

Connecting Your TV

TV, Cable box, and Cable

KV-27FS16, KV-27FV16, KV-32FS16, KV-29FV16 only

For this set up, you can switch between scrambled channels (through your cable box) and normal (CATV) channels by pressing .

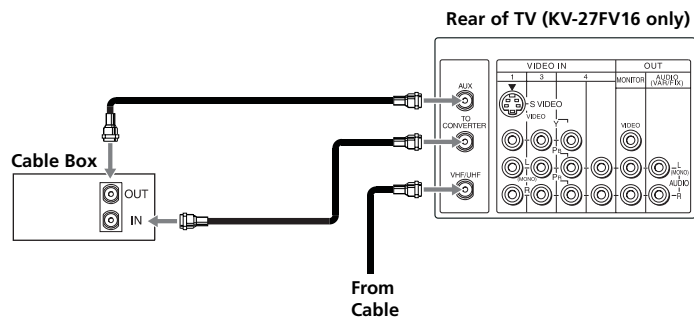

 When using PIP, the AUX input cannot be viewed in the window picture.

7

Operating Instructions

TV, VCR, and Cable box

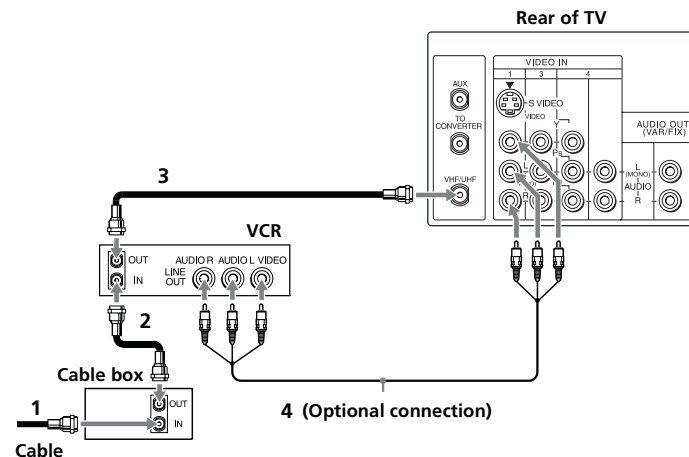



- 1 Connect the coaxial cable from your cable service to the IN jack on your cable box.
- 2 Connect a coaxial cable (not supplied) from the OUT jack on your cable box to the IN jack on your VCR.
- 3 Connect a coaxial cable (not supplied) from the OUT jack on your VCR to the VHF/UHF jack on the TV.

 If you will be controlling all channel selection through your cable box, you should consider using the Channel Fix feature, (see page 26).

(Optional connection)

- 4 If your VCR is equipped with video outputs, you can get better picture quality by connecting A/V cables (not supplied) from AUDIO and VIDEO OUT on your VCR to AUDIO/VIDEO IN on your TV.

 For optimum picture quality, use S VIDEO instead of the yellow A/V cable. S VIDEO does not provide sound, the audio cables must still be connected.

 You can use the  button to switch between the VHF/UHF and VIDEO inputs.

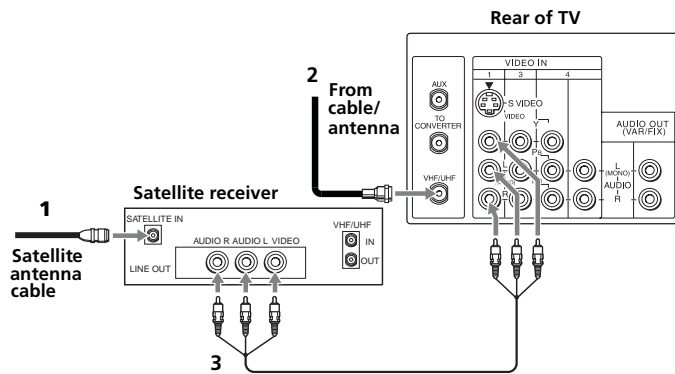

8

TV and Satellite Receiver



- 1** Connect the cable from your satellite antenna to SATELLITE IN on your satellite receiver.
- 2** Connect the coaxial cable from your cable or antenna to the VHF/UHF jack on your TV.
- 3** Using A/V cables, connect AUDIO and VIDEO OUT on your satellite receiver to AUDIO and VIDEO IN on your TV.



 For optimum picture quality, use S VIDEO instead of the yellow A/V cable. S VIDEO does not provide sound, the audio cables must still be connected.

 You can use the  button to switch between the VHF/UHF and satellite receiver inputs.

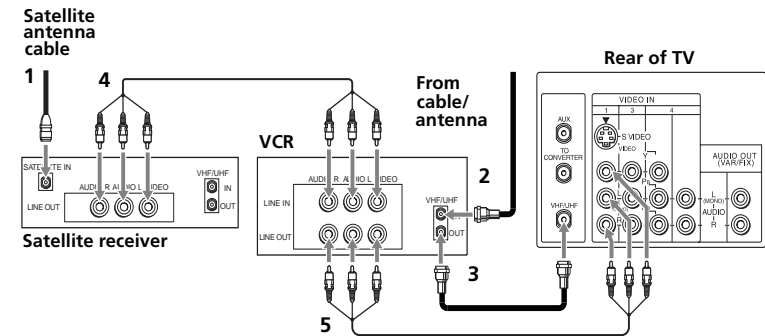
TV, Satellite Receiver, and VCR



- 1** Connect the cable from your satellite antenna to SATELLITE IN on your satellite receiver.
- 2** Connect the coaxial cable from your cable or antenna to the IN jack on your VCR.
- 3** Using a coaxial cable, connect the OUT jack on your VCR to the VHF/UHF jack on your TV.
- 4** Using A/V cables, connect AUDIO and VIDEO OUT on your satellite receiver to AUDIO and VIDEO IN on your VCR.
- 5** Using A/V cables, connect AUDIO and VIDEO OUT on your VCR to AUDIO and VIDEO IN on your TV.

 To view from the satellite receiver or VCR, select the video input to which your satellite receiver or VCR is connected by pressing  on the remote control.

Using the Remote Control and Basic Functions

This section shows you how to use the more advanced buttons on the remote control and how to use the on-screen menus.

Using the Remote Control

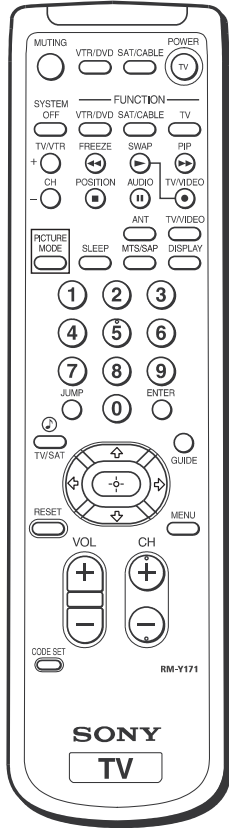

Button	Description
POWER	Press when you want to turn connected equipment on and off.
FUNCTION	Press when you want to control connected equipment with your remote control.
MUTING	Instantly turns off the sound. Press again or press to restore sound.
SYSTEM OFF	Powers off all Sony equipment at once, (may not work with older equipment).
TV/VIDEO	Cycles through available video inputs.
ANT	Press to change the VHF/UHF input to the AUX input (KV-27FS16, KV-27FV16, KV-32FS16 only).
TV/VTR	Press when you are finished using a VCR and you want to switch to the TV input. Your VCR power will remain on.
	Moves the cursor in the on-screen menus. Press the arrow buttons to move the cursor. Press the center button to select or access an option.
PICTURE MODE	Cycles through the available Video Mode settings.

The remote control shown (RM-Y171) is for KV-27FV16. Your remote control may not look like the one illustrated.

Using the Remote Control and Basic Functions

SLEEP	Turns the TV off automatically in approximately 15, 30, 45, 60, 90, or 120 minutes. Cancel by pressing until SLEEP OFF appears.
MTS/SAP	Cycles through the Multi-channel TV Sound (MTS) options: Stereo, Mono, and Auto-SAP (Second Audio Programming).
DISPLAY	Press once to show current time, (if set) and channel number.
JUMP	Cycles through available Steady Sound settings, (see page 23). Alternates between the last two channels selected with the buttons.
GUIDE	Brings up the custom guide of your satellite receiver.
MENU	Displays the on-screen menu. Press again to exit the menu at any time.
RESET	Press to return to factory settings while in an on-screen menu.
CODE SET	Use to program your remote control to operate connected video equipment, (see page 36).













For information on Picture in Picture (PIP) operation buttons, see page 17.

If you lost your remote control, see page 40.

Troubleshooting

If you are having a problem with your TV, try the suggestions below. If the problem persists, contact your nearest Sony dealer.

No picture, no sound	<ul style="list-style-type: none"> <input type="checkbox"/> Make sure the power cord is plugged in. <input type="checkbox"/> If red light is flashing on the front of your TV for more than a few minutes, disconnect and reconnect the power cord to restore the TV. If the problem continues, call your local service center. <input type="checkbox"/> Check the TV/VIDEO settings: when watching TV, set to TV; when watching video equipment, set to VIDEO (page 14). <input type="checkbox"/> Make sure the batteries have been inserted correctly into the remote control (page 2). <input type="checkbox"/> Try another channel, it could be station trouble.
Poor or no picture, good sound	<ul style="list-style-type: none"> <input type="checkbox"/> Adjust Picture in the Video menu (page 22). <input type="checkbox"/> Adjust Brightness in the Video menu (page 22). <input type="checkbox"/> Check the antenna and/or cable connections (page 3).
Good picture, no sound	<ul style="list-style-type: none"> <input type="checkbox"/> Press  so that MUTING disappears from the screen (page 14). <input type="checkbox"/> Check your Audio settings. Your TV may be set to Auto-SAP (page 24).
No color	<ul style="list-style-type: none"> <input type="checkbox"/> Adjust Color in the Video menu (page 22).
No signal	<ul style="list-style-type: none"> <input type="checkbox"/> Check the Cable setting in the Channel Setup menu (page 25). <input type="checkbox"/> Check the antenna and/or cable connections (page 3). <input type="checkbox"/> Make sure the channel selected is currently broadcasting.
Dotted lines or stripes	<ul style="list-style-type: none"> <input type="checkbox"/> Adjust the antenna. <input type="checkbox"/> Move the TV away from other electronic equipment. Some electronic equipment can create electrical noise, which can interfere with TV reception.
Double images or ghosts	<ul style="list-style-type: none"> <input type="checkbox"/> Check your outdoor antenna or call your cable service.

Cannot receive higher number channels (UHF) when using an antenna	<ul style="list-style-type: none"> <input type="checkbox"/> Make sure Cable is set to OFF in the Channel Setup menu (page 25). <input type="checkbox"/> Perform Auto Program to add channels that are not presently in the memory (page 16).
Cable stations don't seem to work	<ul style="list-style-type: none"> <input type="checkbox"/> Make sure Cable is set to ON in the Channel Setup menu (page 25). <input type="checkbox"/> Perform Auto Program to add channels that are not presently in the memory (page 16).
Remote control does not operate	<ul style="list-style-type: none"> <input type="checkbox"/> Batteries could be weak. Replace them (page 2). <input type="checkbox"/> Move the TV 3-4 feet away from fluorescent lights.
The TV needs to be cleaned	<ul style="list-style-type: none"> <input type="checkbox"/> Clean the TV with a soft dry cloth. Never use strong solvents such as thinner or benzine, which might damage the finish of the cabinet.
Lost password for Parental Control	<ul style="list-style-type: none"> <input type="checkbox"/> In the password screen, enter the following master password: 4357. After using the master password, you must create a new password, it cannot be used to unlock currently blocked channels.
You lost your remote control	<ul style="list-style-type: none"> <input type="checkbox"/> You can use the front A/V panel controls to access the menu. Press  to open the menu. Use the  or  buttons on the front A/V panel instead of the  or  buttons on the remote control. Use the  button on the front A/V panel instead of the , , and  buttons on the remote control. Press  again when the setting or adjustment is complete. Contact your nearest Sony dealer to order a replacement.
Cannot access other menus when using the Basic Menu	<ul style="list-style-type: none"> <input type="checkbox"/> If you use the  button to close the Basic menu, only the Basic menu appears when you press  again. To have access to the other menus, use the  button to select Advance Menu (page 35).

If, after reading these Operating Instructions, you have additional questions related to the use of your Sony television, please call our Direct Response Center at 1-800-222-SONY (7669) (U.S. residents only) or (416) 499-SONY (7669) (Canadian residents only).

SECTION 2 DISASSEMBLY

2-1. REAR COVER REMOVAL

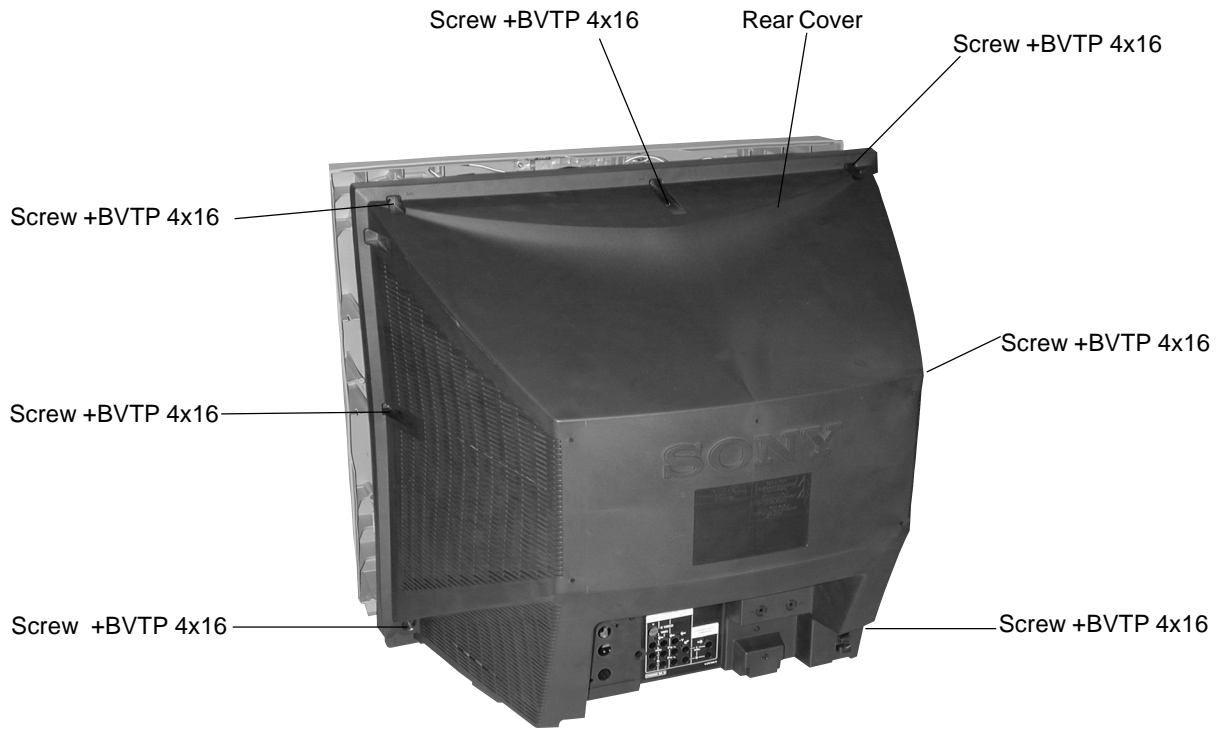

2-2. CHASSIS ASSEMBLY REMOVAL

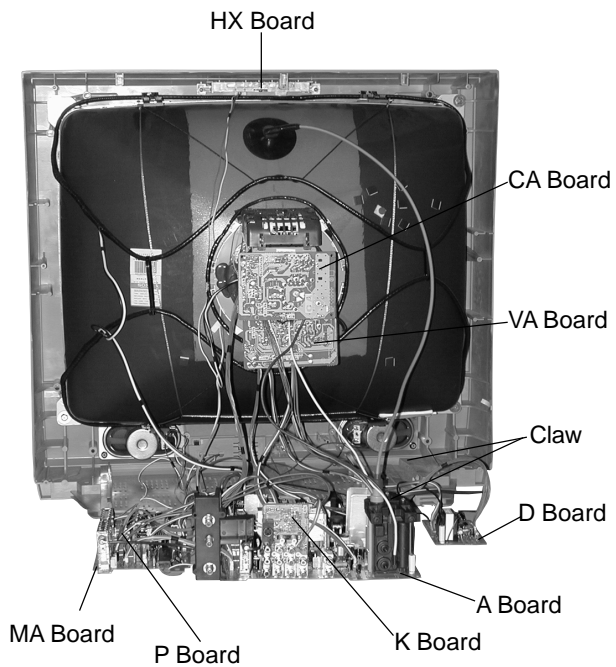

2-3. SERVICE POSITION

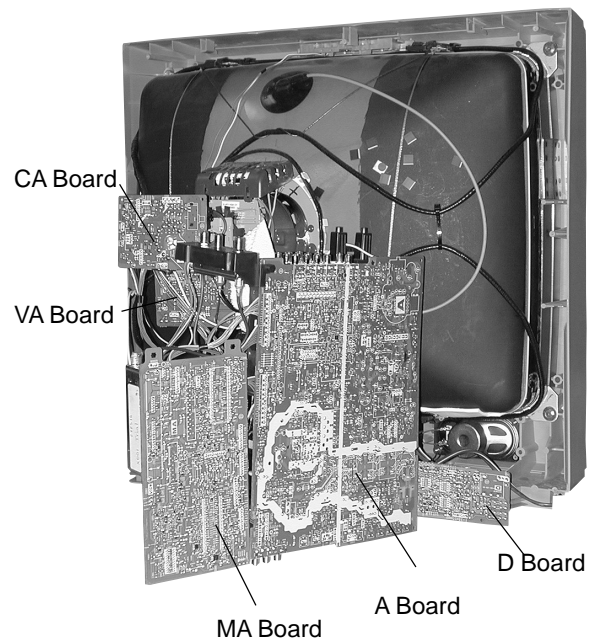

2-4. PICTURE TUBE REMOVAL

**WARNING:
BEFORE REMOVING
THE ANODE CAP**

High voltage remains in the CRT even after the power is disconnected. To avoid electric shock, discharge CRT *before* attempting to remove the anode cap. Short between anode and CRT coated earth ground strap.

Coated Earth Ground Strap

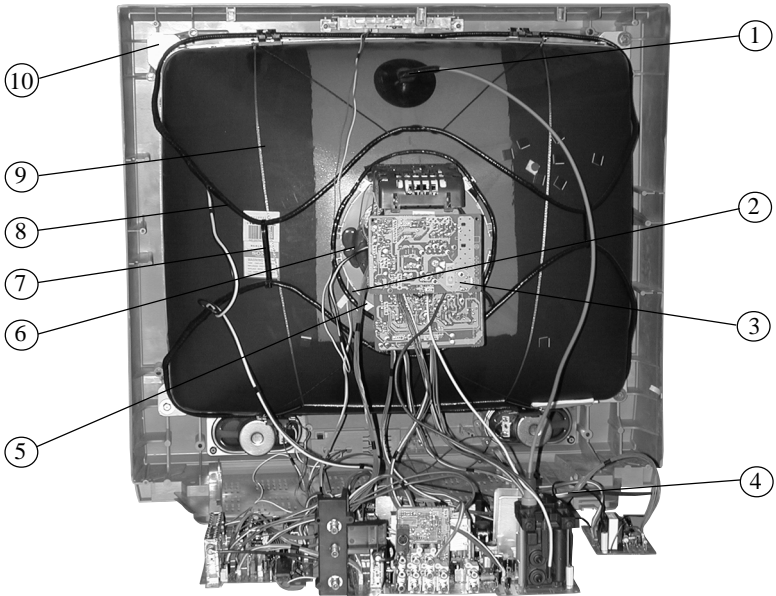

1. Discharge the anode of the CRT and remove the anode cap.
2. Unplug all interconnecting leads from the deflection yoke, neck assembly, degaussing coils and CRT grounding strap.
3. Remove the CA Board from the CRT.
4. Remove the chassis assembly.
5. Loosen the neck assembly fixing screw and remove.
6. Loosen the deflection yoke fixing screw and remove.
7. Place the set with the CRT face down on a cushion and remove the degaussing coil holders.
8. Remove the degaussing coils.
9. Remove the CRT grounding strap and spring tension devices.
10. Unscrew the four CRT fixing screws [located on each CRT corner] and remove the CRT [Take care not to handle the CRT by the neck].

ANODE CAP REMOVAL

WARNING: High voltage remains in the CRT even after the power is disconnected. To avoid electrical shock, discharge the CRT *before* attempting to remove the anode cap. Short between anode and coated earth ground strap of CRT.

NOTE: After removing the anode, short circuit the anode of the picture tube and the anode cap to either the metal chassis, CRT shield, or carbon painted on the CRT.

REMOVAL PROCEDURES

- ① Turn up one side of the rubber cap in the direction indicated by arrow **a**.
- ② Use your thumb to pull the rubber cap firmly in the direction indicated by arrow **b**.
- ③ When one side of the rubber cap separates from the anode button, the anode cap can be removed by turning the rubber cap and pulling it in the direction of arrow **c**.

HOW TO HANDLE AN ANODE CAP

- ① Do not use sharp objects which may cause damage to the surface of the anode cap.
- ② To avoid damaging the anode cap, do not squeeze the rubber covering too hard. A material fitting called a shatter-hook terminal is built into the rubber.
- ③ Do not force turn the foot of the rubber cover. This may cause the shatter-hook terminal to protrude and damage the rubber.

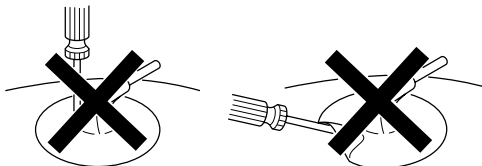

SECTION 3 SET-UP ADJUSTMENTS

The following adjustments should be made when a complete realignment is required or when a new picture tube is installed.

These adjustments should be performed with rated power supply voltage unless otherwise noted.

Set the controls as follows unless otherwise noted:

VIDEO MODE: STANDARD

PICTURE control: Normal

BRIGHTNESS control: Normal

Perform the adjustments in order as follows:

1. Beam Landing
2. Convergence
3. Focus
4. Screen (G2)
5. White Balance

Note: Test equipment required:

- Color Bar Pattern Generator
- Degausser
- DC Power Supply
- Digital Multimeter

3-1. BEAM LANDING

Before beginning adjustment procedure:

1. Degauss the entire screen.
2. Feed in the white pattern signal.

Adjustment Procedure

1. Input a raster signal with the pattern generator.
2. Loosen the deflection yoke mounting screw and set the purity control to the center as shown below.

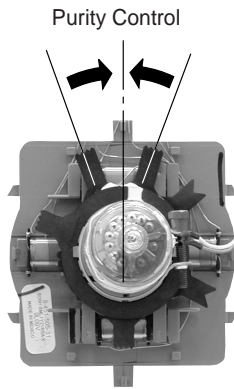

3. Turn the raster signal of the pattern generator to green.
4. Move the deflection yoke backward and adjust the purity control so that green is in the center and red and blue are at the sides evenly.

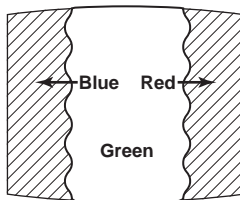

5. Move the deflection yoke forward and adjust so that the entire screen becomes green.
6. Switch over the raster signal to red and blue and confirm the condition.
7. When the position of the deflection yoke is determined, tighten it with the deflection yoke mounting screw.
8. If landing at the corner is not right, adjust by using the disk magnets.

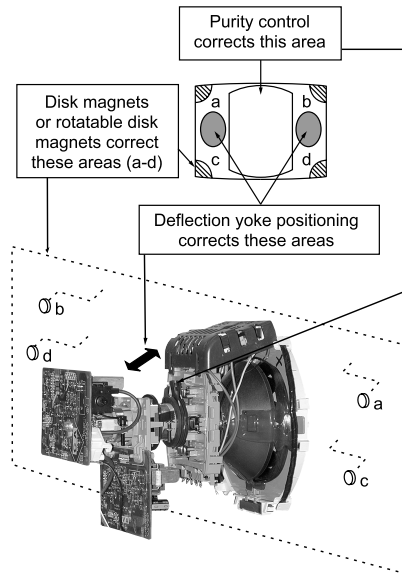
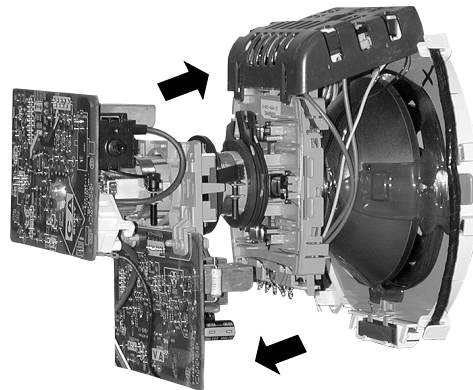

3-2. CONVERGENCE

Before starting convergence adjustments:

1. Perform FOCUS, V.LIN AND V.SIZE adjustments.
2. Set BRIGHTNESS control to minimum.
3. Feed in dot pattern.

Vertical Static Convergence

1. Adjust V.STAT magnet to converge red, green and blue dots in the center of the screen (Vertical movement adjust V.STAT RV 701 to converge).

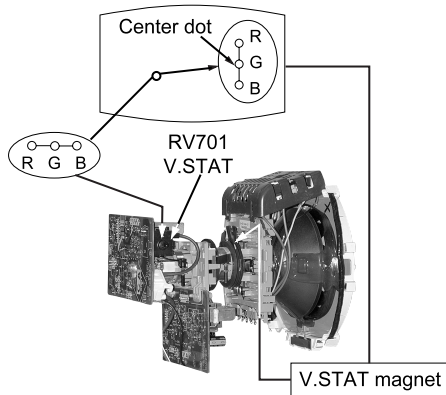

2. Tilt the V.STAT magnet and adjust static convergence to open or close the V.STAT magnet.

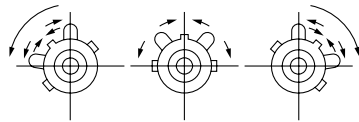

When the V.STAT magnet is moved in the direction of arrows a and b, red, green, and blue dots move as shown below:

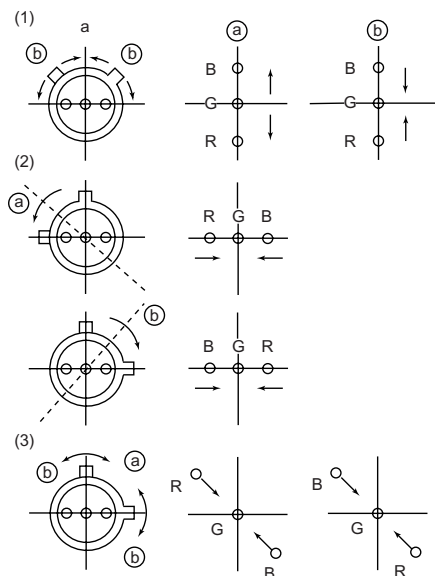

Horizontal Static Convergence

If the blue dot does not converge with the red and green dots, perform the following:

1. Move BMC magnet (a) to correct insufficient H. Static convergence.
2. Rotate BMC magnet (b) to correct insufficient V. Static convergence.
3. After adjusting the BMC magnet, repeat Beam Landing Adjustment.

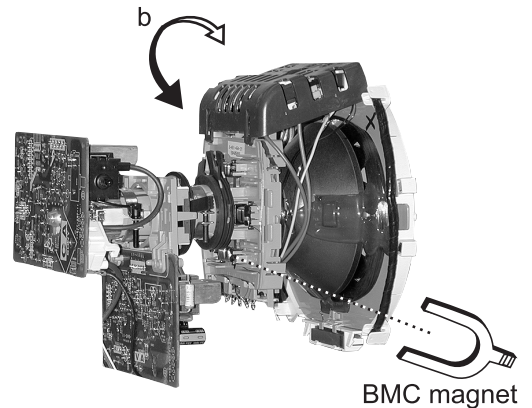
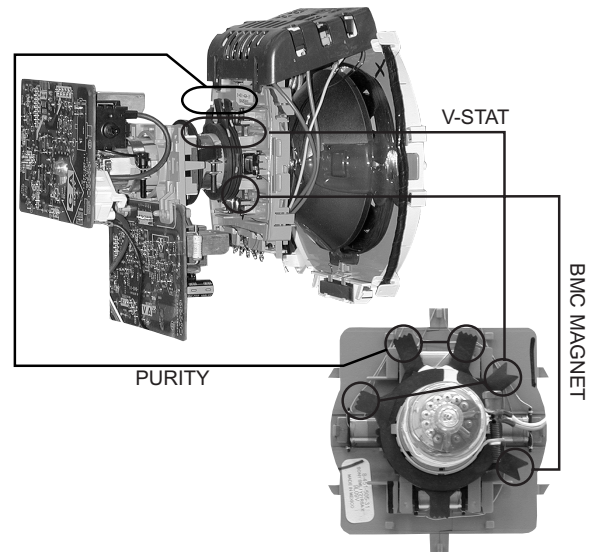

Dynamic Convergence Adjustment

Before performing this adjustment, perform Horizontal and Vertical Static Convergence Adjustment.

1. Slightly loosen deflection yoke screw.
2. Remove deflection yoke spacers.
3. Move the deflection yoke for best convergence as shown on the following page.

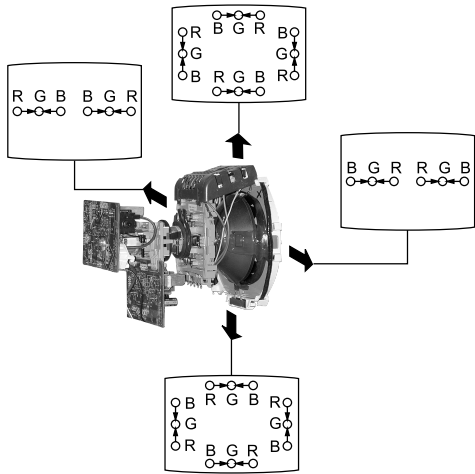

4. Tighten the deflection yoke screw.
5. Install the deflection yoke spacers.

TLH Plate Adjustment

1. Input crosshatch pattern.
2. Adjust PICTURE QUALITY to standard, PICTURE and BRIGHTNESS to 50%, and OTHER to standard.
3. Adjust the Horizontal Convergence of red and blue dots by tilting the TLH plate on the deflection yoke.

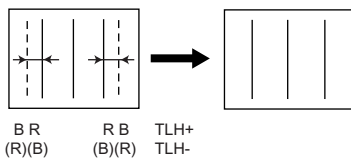
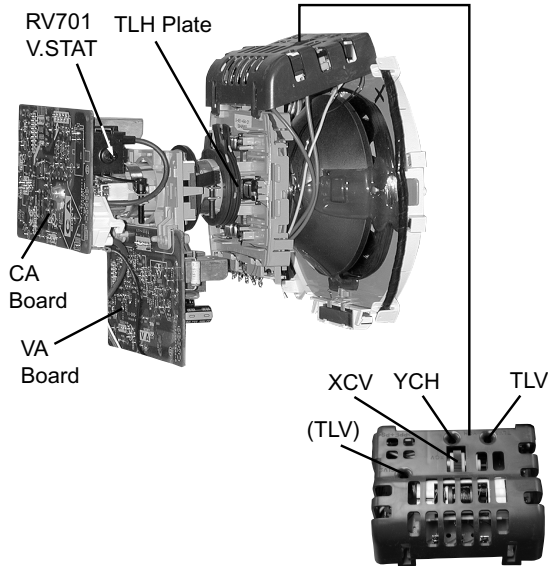

4. Adjust XCV core to balance X axis.
5. Adjust YCH VR to balance Y axis.
6. Adjust vertical red and blue convergence with V.TILT (TLV VR).

Note: Perform adjustments while tracking items 1 and 2.

Screen-Corner Convergence

1. Affix a permalloy assembly corresponding to the misconverged areas.

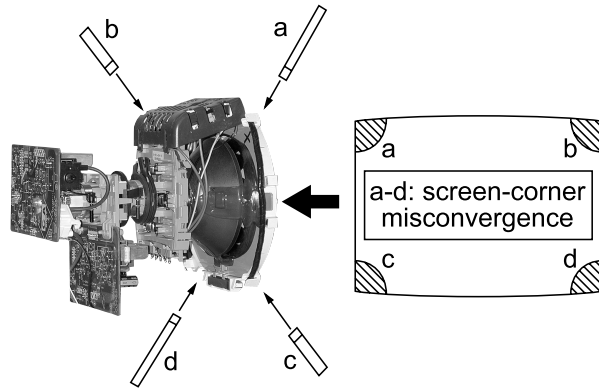

3-3. FOCUS

1. Adjust FOCUS control for best picture.

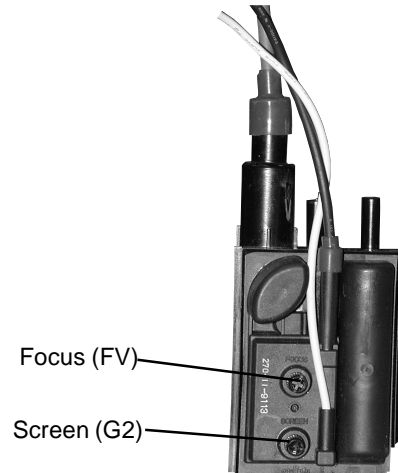

3-4. SCREEN (G2)

1. Input a dots pattern.
2. Set the PICTURE and BRIGHTNESS controls at minimum and COLOR control at normal.
3. Adjust SBRT, GCUT, BCUT in service mode with an oscilloscope as shown below so that voltages on the red, green, and blue cathodes are 170 VDC.

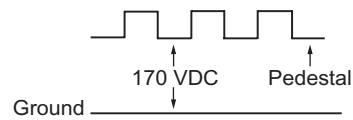

4. Observe the screen and adjust SCREEN (G2) VR in FBT to obtain the faintly visible background of dot signal.

3-5. METHOD OF SETTING THE SERVICE ADJUSTMENT MODE

Service Mode Procedure

1. Standby mode (power off).
2. **Display** → Channel **5** → Sound volume **+** → Power on the Remote Commander (press each button within a second).

Service Adjustment Mode In

1. The CRT displays the item being adjusted.

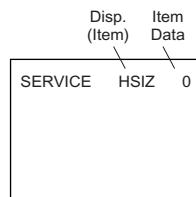

2. Press **1** or **4** on the Remote Commander to select the item.
3. Press **3** or **6** on the Remote Commander to change the data.
4. Press **MUTING** then **ENTER** to save into the memory.

Service Adjustment Mode Memory

Turn set off then on to exit service adjustment mode.

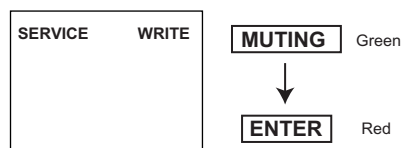

3-6. WHITE BALANCE ADJUSTMENTS

1. Input an entire white signal with burst.
2. Set to Service Adjustment Mode.
3. Set the PICTURE and BRIGHTNESS to minimum.
4. Adjust with SBRT if necessary.
5. Select GCUT and BCUT with **1** and **4**.
6. Adjust with **3** and **6** for the best white balance.
7. Set PICTURE and BRIGHTNESS to maximum.
8. Select GDRV and BDRV with **1** and **4**.
9. Adjust with **3** and **6** for the best white balance.
10. To write into memory, press **MUTING** then **ENTER**.

SECTION 4 SAFETY RELATED ADJUSTMENTS

4-1. ▣ R564 CONFIRMATION METHOD (HV HOLD-DOWN CONFIRMATION) AND READJUSTMENTS

The following adjustments should always be performed when replacing the following components which are marked with ▣ on the schematic diagram:

Part Replaced (▣)	Adjustment (▣)
DY, T505, CRT, IC501, C507, C520, C505, C509, C515, T504, T503, C551, L510, C546, C537, C547, D517, D518, D519, R560, R561, R562, R563, R565, R566, R567, R525 A Board	HV HOLD-DOWN R564
IC301 MA Board	

Preparation Before Confirmation

- Using a Variac, apply AC input voltage: $120-220 \pm 2$ VAC.
- Turn the POWER switch ON.
- Input a white signal and set the PICTURE and BRIGHTNESS controls to maximum.
- Confirm that the voltage between C546 (+) or TP503 and ground is more than 21.0 VDC.

Hold-Down Operation Confirmation

- Connect the current meter between Pin 11 of the FBT (T505) and the PWB land where Pin 11 would normally attach. (See Figure 1 on the next page.)
- Input a dot signal and set PICTURE and BRIGHTNESS to minimum: $IABL = 1730 \pm 100 \mu A$.
- Confirm the voltage of A Board TP-600 is 135 ± 1.5 VDC.
- Connect the digital voltmeter and the DC power supply via diode 1SS119 to C546 (+) and ground. (See Figure 1 on the next page.)
- Increase the DC power voltage gradually until the picture blanks out.
- Turn DC power source off immediately.
- Read the digital voltmeter indication (standard $< 24.78+0,-0.1$ VDC).
- Input a white signal and set PICTURE and BRIGHTNESS to maximum: $IABL = 1730 \pm 100 \mu A$.
- Repeat steps 4 to 7.

Hold-Down Readjustment

If the setting indicated in step 2 of Hold-Down Operation Confirmation cannot be met, readjustment should be performed by altering the resistance value of R564 component marked with ▣.

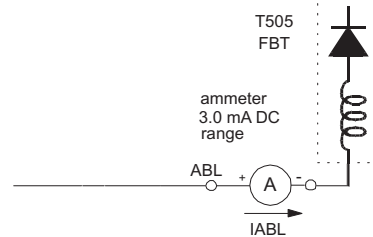

4-2. B+ VOLTAGE CONFIRMATION AND ADJUSTMENT

Note: The following adjustments should always be performed when replacing the following components, which are marked with ▣ on the schematic diagram on the A Board.

A BOARD: IC601, PH601

- Using a Variac, apply AC input voltage: 130 ± 2 VAC.
- Input a dot signal.
- Set the PICTURE and BRIGHTNESS controls to minimum.
- Confirm that the voltage of A Board TP-600 is < 136.5 VDC.
- If step 3 is not satisfied, replace the components listed above, then repeat steps 1–3.

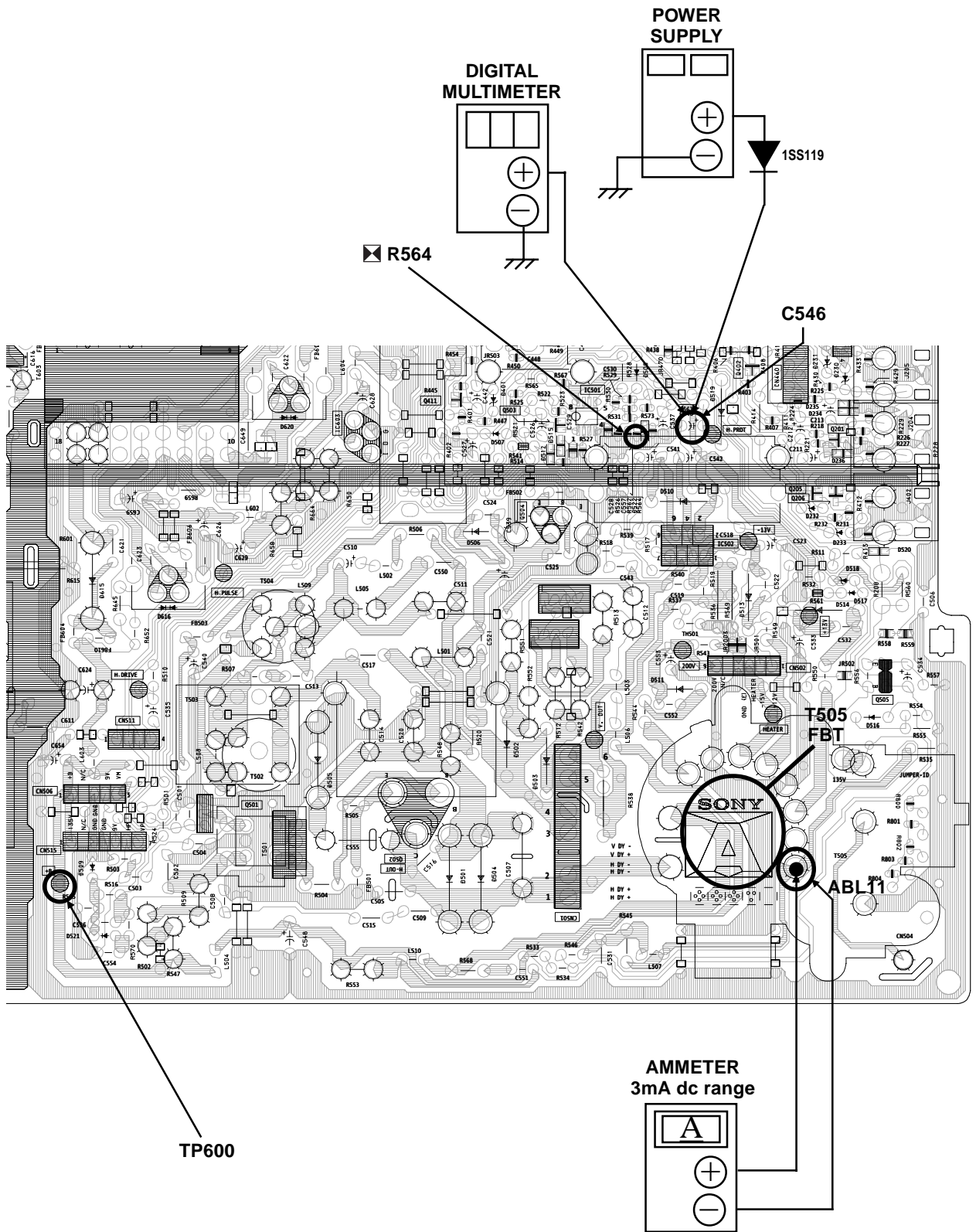

Figure 1

SECTION 5 CIRCUIT ADJUSTMENTS

ELECTRICAL ADJUSTMENTS BY REMOTE COMMANDER

Use the Remote Commander (RM-Y168 or RM-Y169) to perform the circuit adjustments in this section.

NOTE: Test Equipment Required:

- Pattern generator
- Frequency counter
- Digital multimeter
- Audio oscillator

5-1. SETTING THE SERVICE ADJUSTMENT MODE

1. Standby mode (power off).
2. **Display** → Channel **5** → Sound volume **+** → Power on the Remote Commander (press each button within a second).

Service Adjustment Mode On

1. The CRT displays the item being adjusted.

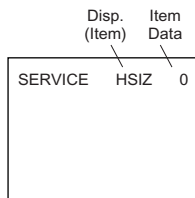

2. Press **1** or **4** on the Remote Commander to select an item.
3. Press **3** or **6** on the Remote Commander to change the data.
4. Press **MUTING** then **ENTER** to save into the memory.

Service Adjustment Mode Memory

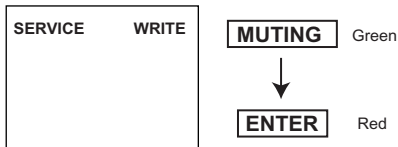

1. Press **8** then **ENTER** on the Remote Commander to initialize.

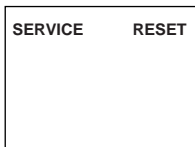

Carry out step 1 when adjusting IDs 0–4 and when replacing and adjusting IC003.

2. Turn set off then on to exit service adjustment mode.

5-2. MEMORY WRITE CONFIRMATION METHOD

1. After adjustment, remove the power plug from the AC outlet, then plug it in again.
2. Turn the power switch ON and set to service mode.
3. Call the adjusted items again to confirm they were adjusted.

5-3. ADJUSTMENT BUTTONS AND INDICATORS

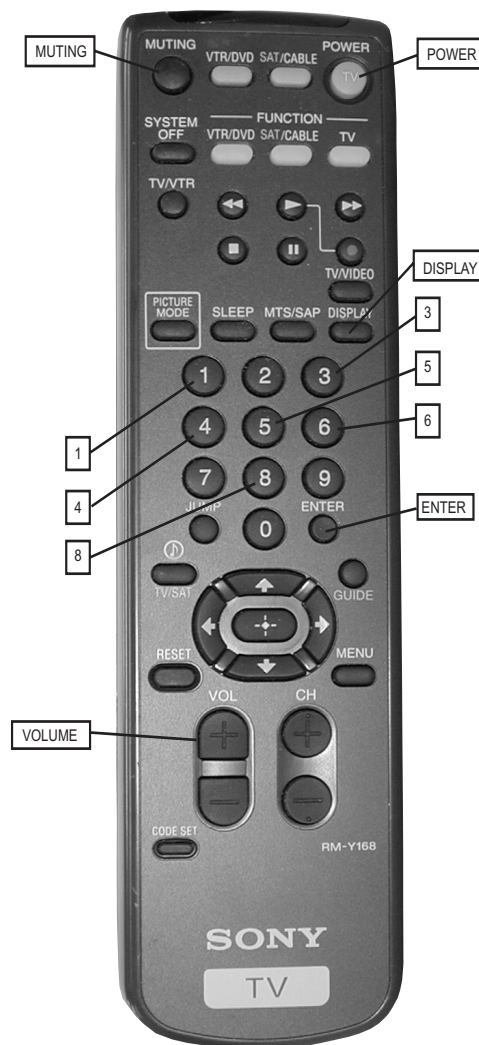

RM-Y168

Adjustment Items

Reg #	ITEM	FUNCTION	RANGE	FIX DATA	NTSC	PAL M	PAL N	VIDEO	RF	AVERAGE DATA
1	HSIZ	Horizontal Size Adjustment	0-63		15	12	7			14
2	HPOS	Horizontal Position Adjustment	0-63		13	8	9			17
3	VBOW	Vertical Line Bowing Adj.	0-15		9	10	8			6
4	VANG	Vertical Line Bowing Slant Adj.	0-15		8	10	9			12
5	VTRP	TRAPEZIUM	0-31		19	14	14			16
6	HTRP	Horiz. Trapezoid	0-15		6	7	5			0
7	TROT	Tilt Correction	0-63		31	31	31			31
8	PAMP	Horizontal PIN distortion Adj.	0-63		19	19	21			20
9	UPIN	Upper PIN Distortion Adj.	0-63		34	33	36			35
10	LPIN	Lower PIN Distortion Adj.	0-63		32	34	40			34
11	VSIZ	Vertical Size Adjustment	0-63		32	43	29			38
12	VPOS	Vertical Position Adj.	0-63		30	30	32			29
13	VLIN	Vertical lineality Adj.	0-15		3	6	10			5
14	SCOR	Vertical "S" Correction Adjustment	0-15		6	8	10			7
15	VZOM	16:9 CRT Z Mode on/off	0-1	0						0
16	EHT	Vertical High-Voltage Compensation	0-15	5						5
17	ASP	Aspect Ratio control	0-63	47						47
18	SCRL	16:9 CRT Z Mode Trans. Scroll	0-63	31						31
19	HBLK	Horizontal Blanking on/off	0-1	1						1
20	LBLK	Left Blanking Adjustment	0-15	13						14
21	RBLK	Rigth Blanking Adjustment	0-15	8						8
22	HDW	Horizontal Drive Pulse Width		1						1
23	EWDC	"Parabola" EW, D.C. Adjustment	0-1	0						0
24	LVLN	Lower Screen BTM Vertical Line Adj.	0-15	0						0
25	UVLN	Uppe Screen BTM Vertical Line Adj.	0-15	0						0
26	INTL	INTERLACE	0-3	0						0
27	G2SW		0-1	0						0
28	G2LV		0-7	0						0
29	HOOSC	Horizontal VCO Oscillation Freq.	0-15	7						7
30	VSS	Vertical Sync Slice Level	0-3	0						0
31	HSS	Horizontal Sync Slice Level	0-1	0						0
32	HMSK	For Macro Vision	0-1	0						0
33	VTMS	Select Signal VTIM Pin	0-3	0						0
34	CDMD	Vertical Count Down Mode Switching	0-3		*	*	*	3		3
35	AFC	AFC Loop Gain Switching	0-3	0						0
36	FIFR	Field Frequency	0-3	3						3
37	VBLK	VBLKW	0-3	0						0
38	REFP	REFP	0-1	0						0
39	JPSW	JUMPSW	0-1	MENU						0
40	RDRV	R Output Drive control	0-63	41						38
41	GDRV	G Output Drive control	0-63	25						28
42	BDRV	B Output Drive control	0-63	25						26
43	RCUT	R Output Cutoff control	0-63	31						31
44	GCUT	G Output Cutoff control	0-63	15						13
45	BCUT	B Output Cutoff control	0-63	12						14
46	SCON	SUB CONT	0-15	8						10
47	SHUE	Sub HUE adjustment	0-15	16						16
48	SCOL	Sub COLOR adjustment	0-15	18						18
49	SBRT	Sub BRIGHTNESS adjustment	0-31	16	16	16	16			17
50	CHUE	SUB COLOR (RF)	0-31	7						6
51	CCOL	SUB COLOR (RF)	0-31	7						4
52	UOFS	YUV U OFFSET	0-15	7	7	7	7			7
53	VOFS	YUV V OFFSET	0-15	7						7
54	RON	R Output on/off	0-1	1						1
55	GON	G Output on/off	0-1	1						1
56	BON	B Output on/off	0-1	1						1
57	AXPL	Axis PAL	0-1	0						0
58	AXNT	Axis NTSC	0-1	1						1
59	CBPF	Chroma BPF on/off	0-1	1						1
60	CTRP	Y TRAP FILTER on/off	0-1	1						1
61	COFF	Color On/off	0-1	0						0
62	KOFF	Set Color Killer	0-1	0						0
63	SSHP	Sub SHARPNESS	0-15	5						5
64	SHPF	SHARPNESS Circuit Fo	0-3	Palette						2
65	PREL	Pre-Shoot/ Over-Shoot	0-1	1						0
66	Y-DC	DC transimtion Ratio Switching	0-3	Palette						2
67	GAMM	Gamma Correction	0-3	Palette						2
68	ABLM	ABL Mode Switch	0-1	1						1
69	VTH	ABL CD VHT Switching	0-1	1						1
70	YDEL	Y Delay Time Control	0-15	7						7
71	NCOL	No Color ID	0-1	1						1
72	FSC	FSC Out on/off	0-1	1						1
73	K-ID	Killer ID Control on/off	0-1	0						0
74	GDOF		0-31	3						3
75	BDOF		0-31	16						16
76	GCOF		0-31	16						16
77	BCOF		0-31	7						7
78	SYSC	Color System	0-7	4						4
79	VENH	Vertical Enhancement	0-7	Palette						3

KV-27FS12/27FS16/29FS12/29FS12C

Reg #	ITEM	FUNCTION	RANGE	FIX DATA	NTSC	PAL M	PAL N	VIDEO	RF	AVERAGE DATA
80	PDSO	PDS OFF	0-1	0						0
81	CK	CK	0-1	0						0
82	VNL	VNL	0-15	3						3
83	HPK	HPK	0-1	0						0
84	HPKO	HPK OFF	0-1	Palette						0
85	CORE	CORE	0-3	2						1
86	TRAP	TRAP	0-1	1						1
87	CHTR	CH TRAP	0-1	0						0
88	CBPF	CBPF	0-1	1						1
89	ENHO	ENHOFF	0-1	0						0
90	NMRD	NMRD	0-3	0						0
91	YAPS	YAPS	0-3	3						3
92	CLKS	CLKS	0-3	0						0
93	NSTD	NSTD	0-3	0						0
94	MSS	MSS	0-3	0						0
95	KILS	KILS	0-3	1						1
96	ADIN	ADIN	0-1	0						0
97	EXCS	EXCSS	0-3	1						1
98	CPP	CPP	0-3	2						2
99	HDP	HDP	0-7	4						4
100	CDL	CDL	0-7	4						4
101	DYCR	DYCOR	0-15	2						2
102	DYGN	DYGAIN	0-15	10						10
103	DCCR	DCCOR	0-15	3						3
104	DCGN	DCGAIN	0-15	6						6
105	YNRL	YNRLIM	0-3	1						1
106	CNRL	CNRLIM	0-3	1						1
107	WSC	WSC	0-3	1						1
108	VTRH	VTRH	0-3	1						1
109	VTRR	VTRR	0-3	1						1
110	LDSR	LDSR	0-3	2						2
111	VAPG	VAPGAIN	0-7	3						3
112	VAPI	VAPINV	0-31	6						6
113	TEST	TEST	0-1	0						0
114	YPFT	YPFT	0-3	3						3
115	YPFG	YPFG	0-15	7						7
116	CC3N	CC3N	0-1	0						0
117	SELD	SELD	0-1	1						1
118	D2GN	D2GAIN	0-7	5						5
119	YHCR	YHCOR	0-3	0						0
120	YPFC	YPFCOR	0-1	0						0
121	SHT	SHT	0-3	0						0
122	MVT	MVT	0-1	0						0
123	OTT	OTT	0-1	0						0
124	CL2D	CL2D	0-1	1						1
125	CLKG	CLKGGT	0-1	0						0
126	HPLL	HPLLFS	0-1	1						1
127	BPLL	BPLLFS	0-1	0						0
128	FSCF	FSCFG	0-1	0						0
129	PLLS	PLLS	0-1	1						1
130	KILR	KILR	0-15	3						3
131	HSSL	HSSL	0-15	12						12
132	VSSL	VSSL	0-15	8						8
133	BGPS	BGPS	0-15	4						4
134	BGPW	BGPW	0-15	10						10
135	ADCK	ADCLKS	0-3	3						3
136	NDSW	NDSW	0-1	1						1
137	PFRN	FREE_RUN	0-1	0						0
138	PRVS	RVS	0-1	0						0
139	PCON	CONTRAST	0-127	45						45
140	PUCO	U-DAC	0-127	16						16
141	PVCO	V-DAC	0-127	24						24
142	PHUE	PHUE	0-31	15						15
143	PKIL	KILLER	1	0						0
144	PSEP	EXT_SC_SEL	0-3	2						2
145	PHIM	PHIM	0-1	0						0
146	PSUB	PSUB	0-1	0						0
147	PBGS	BG_START	0-63	14						14
148	PDL0	PDL0	0-15	6						6
149	PDL1	PDL1	0-15	13						13
150	PBRT	Y_OFFSET	0-31	25						25
151	PVP1	PVP1		0						0
152	PUP1	PUP1		0						0
153	PVP2	PVP2		2						0
154	PUP2	PUP2		2						0
155	PVP3	PVP3		2						0
156	PUP3	PUP3		2						0
157	PACS	SET_ACC	0-1	1						1
158	PSDL	SYNC_DELAY	0-3	0						0

Reg #	ITEM	FUNCTION	RANGE	FIX DATA	NTSC	PAL M	PAL N	VIDEO	RF	AVERAGE DATA
159	PDCO		0-3	0						0
160	PCGA	C_GAIN	0-1	1						1
161	PAAF		0-1	0						0
162	PSU2		0-1	0						0
163	PCVF		0-1	0						0
164	PBIT	BITSEL	0-1	0						0
165	PAFC	AFCBITSEL	0-1	0						0
166	PACC	ACC_LEVEL	0-63	22						22
167	PBUR	BURST_CLK	0-1	0						0
168	PEVE	EVENUPRA	0-1	0						0
169	PINW	INV_WFF	0-1	0						0
170	PINR	INV_REF	0-1	0						0
171	PREF	RFF_FIX	0-1	0						0
172	PARE	AUTO_REF	0-1	1						1
173	PAVE	AVERAGE	0-1	0						0
174	PFRA	FREE_RUN_ADJ	0-15	0						0
175	PPAL	SUB_PALM_JUDGE	0-255	0						0
176	PHPO		0-31	6						6
177	PVPO		0-31	22						22
178	PHTI	HT	0-15	7						9
179	PHAJ	ADJ	0-15	1						1
180	PBGY	BGY	0-15	0						0
181	PCRO	CROSS_SEL	0-1	0						0
182	PPAR	PALRY	0-63	2						2
183	PHPF	HPFOFF	0-1	0						0
184	PFSC	FSC_OUTPUT	0-1	0						0
185	PVCH	SET_VCHIP	0-1	0						0
186	PVON	VCHIP_ONLY	0-1	1						1
187	PVLN	LINE_NUM	0-31	17						17
188	PVSB	STB_DLY	0-255	64						64
189	PVLV	L_LEVEL	0-255	130						130
190	SBAL	Sub Balance	0-7	5						5
191	SBAS	Sub Bass	0-7	0						0
192	STRE	Sub Treble	0-7	3						3
193	BBEL	BBE Low	0-15	0	0					0
194	BBEH	BBE High	0-15	0	0					0
195	BBE	BBE	0-1	0	0					0
196	AUX	SRS, Simulated	0-3	0	0					0
197	DISP	O.S.D Display position	0-127	20						34
198	HCLW	Horizontal Count lower limit	0-255	16				16		16
199	HCHG	Horizontal Count High limit	0-255	64	0	0		64		64
200	ID0		0-255	89			1			See ID Map
201	ID1		0-255	31						See ID Map
202	ID2		0-255	79						See ID Map
203	ID3		0-255	146						See ID Map
204	ID4		0-255	137						See ID Map
205	ID5		0-255	19						See ID Map
206	ID6		0-255	0						See ID Map

* CDMD = 3 For US & CND, CDMD = 0 For Others

Notes:

No. 1–206 show the order that each adjustment mode may be selected while in service mode.

Data Range shows the range of possible settings for each adjustment mode.

Initial Data shows the standard settings for each adjustment mode.

SERVICE	ID0	25

Feature ID Map

	Destination	ID-0	ID-1	ID-2	ID-3	ID-4	ID-5	ID-6
KV-27FS12	(US)	89	31	79	146	137	19	0
KV-27FS12	(CND)	89	31	79	178	137	19	0
KV-27FS16	(US)	89	31	79	146	137	19	7
KV-29FS12	(E)	17	31	223	130	233	19	0
KV-29FS12C	(E)	17	31	223	130	233	19	0

5-4. MA BOARD ADJUSTMENTS

H. Frequency (Free Run) Check

1. Input a TV mode (RF) with no signal.
2. Connect a frequency counter to base of Q501 (TP-500 H. DRIVE) on the A Board.

3. Check H. Frequency for 15735 ± 200 Hz.

V. Frequency (Free Run) Check

1. Select video 1 with no signal input.
2. Set the conditions for a standard setting.
3. Connect the frequency counter to TP-502 (V OUT) or CN501 pin ⑥ (V DY+) and ground on the A Board .
4. Check that V. Frequency shows 60 ± 4 Hz.

Drive (RDRV)

1. Input a color-bar signal and set the level to 75%.
2. Set in Standard mode.

3. Activate the Service Adjustment Mode. 4. Set both GON and BON items. Using [3] and [6]; set each to the following values. Leave RON set to "1".

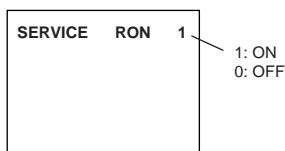

R ON: ON (1)
 G ON: OFF (0)
 B ON: OFF (0)

5. Connect an oscilloscope probe to CA Board, J701 Pin 12 (KR) (Red Out).
6. Select RDRV with [1] and [4].
7. Adjust the value of RDRV with [3] and [6] for 92.5 ± 3 VDC.

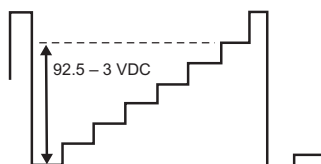

8. Reset GON and BON values to "1".

R ON: ON (1)
 G ON: ON (1)
 B ON: ON (1)

9. Press [MUTING] then [ENTER] to save into the memory.

Display Position Adjustment (DISP)

1. Input a color-bar signal.
2. Set to Service Adjustment Mode.
3. Select DISP with [1] and [4].
4. Adjust values of DISP with [3] and [6] to adjust characters to the center.
5. Write to memory by pressing [MUTING] then [ENTER].
6. Check to see if the text is displayed on the screen.

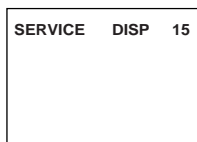

Sub Bright Adjustment (SBRT)

1. Input a monoscope signal.
2. Activate the Service Adjustment Mode.
3. Set the PICTURE and BRIGHTNESS to minimum.
4. Select the SBRT item with [1] and [4].
5. Adjust the values of SBRT with [3] and [6] to obtain a faintly visible crosshatch.
6. Press [MUTING] then [ENTER] to save into the memory.

Sub Hue, Sub Color Adjustment (CHUE, CCOL)

1. Input a color-bar signal.
2. Activate the Service Adjustment Mode.
3. Connect an oscilloscope probe to CA Board, CN1752 Pin [4].
4. Select the CHUE and CCOL item with [1] and [4].
5. While showing the CHUE item, adjust the waveform with [3] and [6] until the second and third bars show the same level ($V2 = V3 < 0.1$ Vp-p).
6. While showing the CCOL item, adjust the waveform with [3] and [6] until the first and fourth bars show the same level ($V1 = V4 < 0.1$ Vp-p).

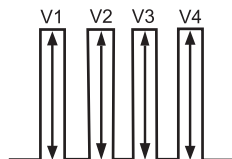

7. Press [MUTING] then [ENTER] to save into the memory.

V. Size Adjustment (VSIZ)

1. Input a crosshatch signal.
2. Activate the Service Adjustment Mode.
3. Select the VSIZ item with [1] and [4].
4. Adjust value of VPOS with [3] and [6] for the best vertical center.
5. Press [MUTING] then [ENTER] to save into the memory.

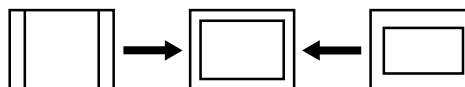

V. Center Adjustment (VPOS)

Perform this adjustment after performing H. Frequency (Free Run) Check.

1. Input a crosshatch signal.
2. Activate the Service Adjustment Mode.
3. Select the VPOS item with [1] and [4].
4. Adjust value of VPOS with [3] and [6] for the best vertical center.
5. Press [MUTING] then [ENTER] to save into the memory.

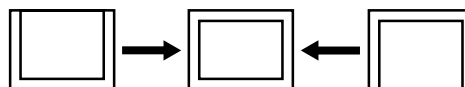

H. Center Adjustment (HPOS)

Perform this adjustment after performing H. Frequency (Free Run) Check.

1. Input a crosshatch signal.
2. Activate the Service Adjustment Mode.
3. Select the HPOS item with [1] and [4].
4. Adjust the value of HPOS with [3] and [6] for the best

horizontal center.

- 5. Press **MUTING** then **ENTER** to save into the memory.

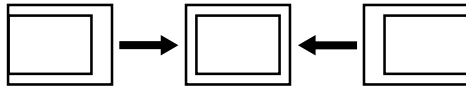

H. Size Adjustment (HSIZ)

- 1. Input a monoscope signal.
- 2. Activate the Service Adjustment Mode.
- 3. Select HSIZ with **1** and **4**.
- 4. Adjust with **3** and **6** for the best horizontal size.
- 5. Press **MUTING** then **ENTER** to save into the memory.

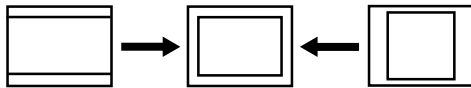

V. Linearity (VLIN), V. Correction (VSCO), Pin Amp (PAMP), and Horizontal Trapezoid (TRAP) Adjustments

- 1. Input a crosshatch signal.
- 2. Activate the Service Adjustment Mode.
- 3. Select VLIN, VSCO, PAMP, and PPHA with with **1** and **4**.
- 4. Adjust with **3** and **6** for the best horizontal size.
- 5. Press **MUTING** then **ENTER** to save into the memory.

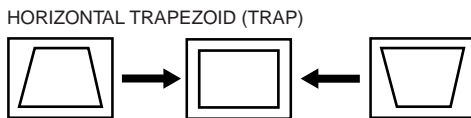
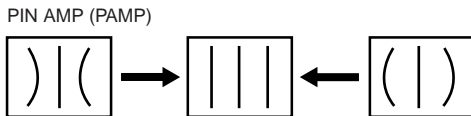
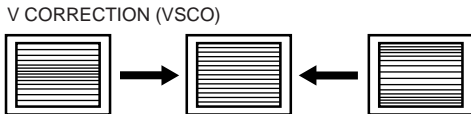
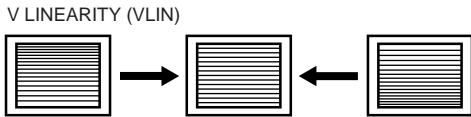

V. Angle (VANG), V. Bow (VBOW), Upper pin (UPIN) and Low Pin (LPIN) Adjustments

- 1. Input a crosshatch signal.
- 2. Activate the Service Adjustment Mode.
- 3. Select VANG, VBOW, UPIN, and LPIN with **1** and **4**.
- 4. Adjust with **3** and **6** for the best picture.
- 5. Press **MUTING** then **ENTER** to save into the memory.

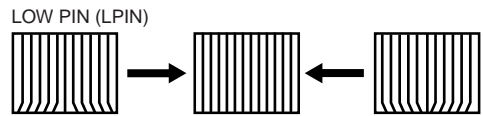
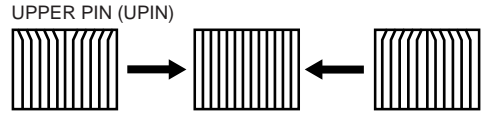
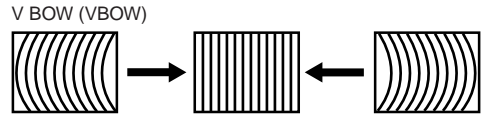
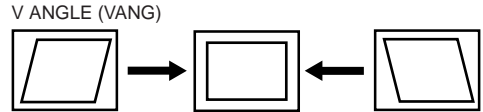

Service Adjustment Mode Memory

- 1. Change the value of the DCOL item to "1".
- 2. After completing all adjustments, press **0** then **ENTER**.

Read From Memory

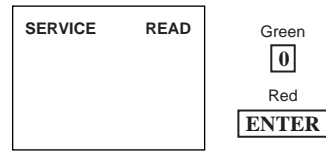

SECTION 6
DIAGRAMS

6.1 BLOCK DIAGRAM

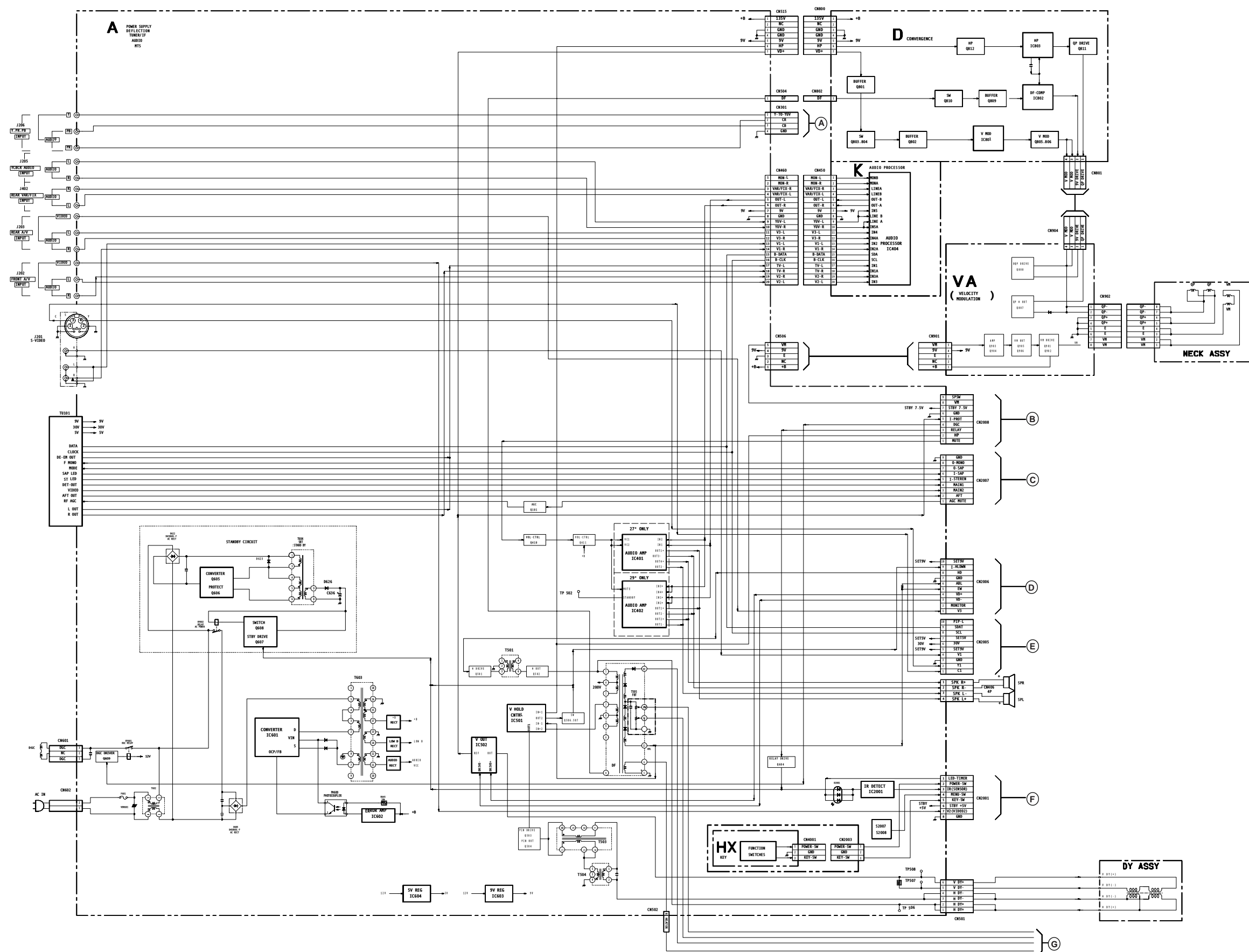

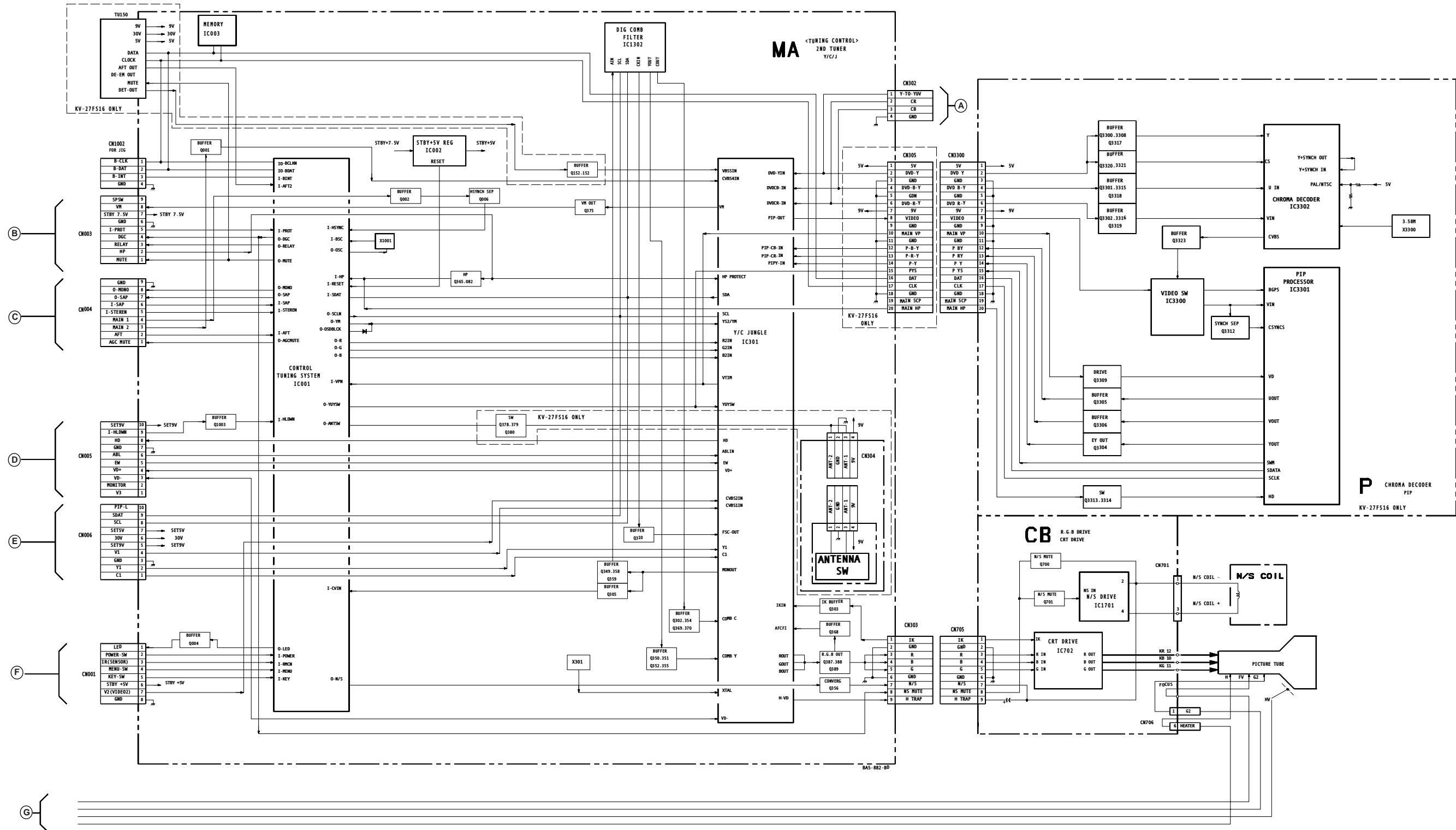

6.2 CIRCUIT BOARD LOCATIONS

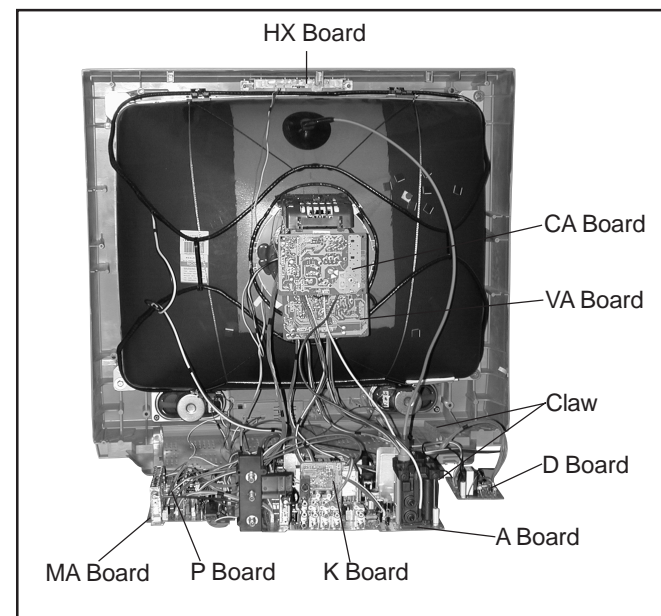

Part Replaced (▣)	Adjustment (▶)
DY, T505, CRT, IC501, C507, C520, C505, C509, C515, T504, T503, C551, L510, C546, C537, C547, D517, D518, D519, R560, R561, R562, R563, R565, R566, R567, R525.....A Board	HV HOLD-DOWN (R564)
IC301.....MA Board	
IC601, PH601.....A Board	B+ VOLTAGE CONFIRMATION

- All voltages are in Volts
- Voltage is DC with respect to ground unless otherwise noted.
- Readings are taken with a 10MΩ digital multimeter.
- Readings are taken with a color-bar signal input.
- Voltage variations may be noted due to normal production tolerance.
- Circled numbers are waveform references.
- * : cannot be measured
- — : B + Line
- - - - : B - Line
- ⇨ : Signal path

Reference Information

RESISTOR	: RN	METAL FILM
	: RC	SOLID
	: FPRD	NON FLAMMABLE CARBON
	: FUSE	NON FLAMMABLE FUSIBLE
	: RW	NON FLAMMABLE WIREWOUND
	: RS	NON FLAMMABLE METAL OXIDE
	: RB	NON FLAMMABLE CEMENT
	: *	ADJUSTMENT RESISTOR
COIL	: LF-8L	MICRO INDUCTOR
CAPACITOR	: TA	TANTALUM
	: PS	STYROL
	: PP	POLYPROPYLENE
	: PT	MYLAR
	: MPS	METALIZED POLYESTER
	: MPP	METALIZED POLYPROPYLENE
	: ALB	BIPOLAR
	: ALT	HIGH TEMPERATURE
	: ALR	HIGH RIPPLE

Note:

The components identified by ▣ in this manual have been carefully factory-selected for each set in order to satisfy regulations regarding X-ray radiation. Should replacement be required, replace only with the value originally used.

When replacing components identified by ▣, make the necessary adjustments indicated. If results do not meet the specified value, change the component identified by ▶ and repeat the adjustment until the specified value is achieved (refer to Safety Related Adjustments on page 20).

When replacing parts shown in the table below, be sure to perform the related adjustments.

The components identified by shading and Δ mark are critical for safety. Replace only with the part number specified.
The symbol (displayed on component side of the circuit board) indicates fast operating fuse. Replace only with fuse of the same rating as marked.

Les composants identifiés per un tramé et une marque Δ sont critiques pour la sécurité. Ne les remplacer que par une pièce portant le numéro spécifié. Le symbole indique une fusible a action rapide. Doit être remplacée par une fusible de meme yaleur, comme marque.

A BOARD IC BLOCK DIAGRAMS

A BOARD: IC401 TDA7057AQ/N2 (KV-27FS12/27FS16 ONLY)

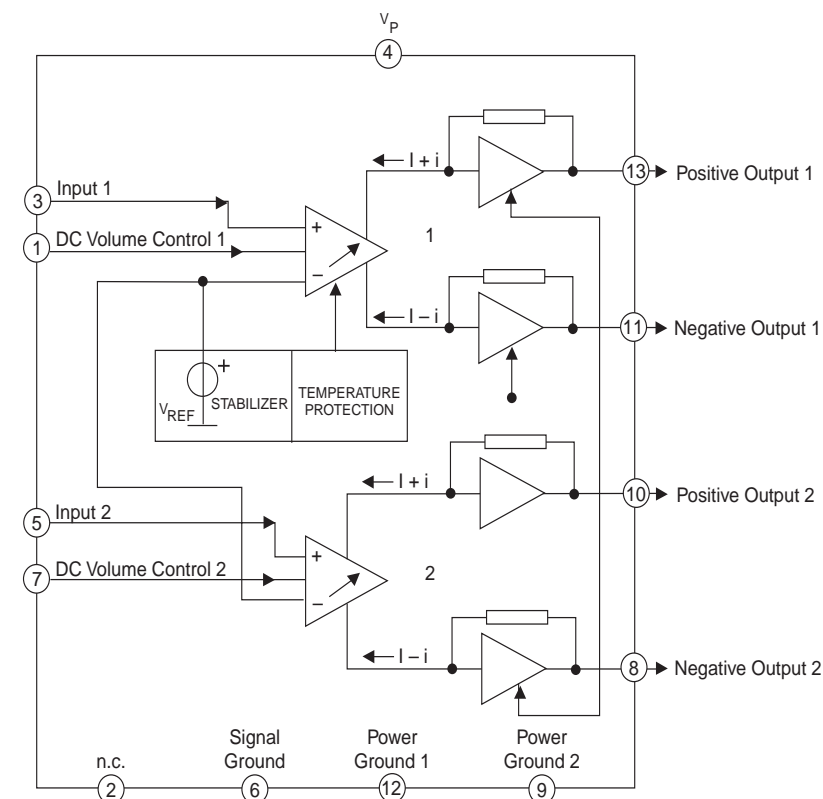

A BOARD: IC502 TDA8172

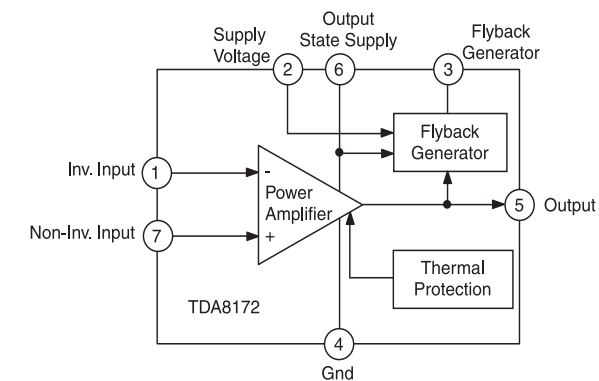

A BOARD: IC402 TDA8580Q/N1 (KV-29FS12/29FS12C ONLY)

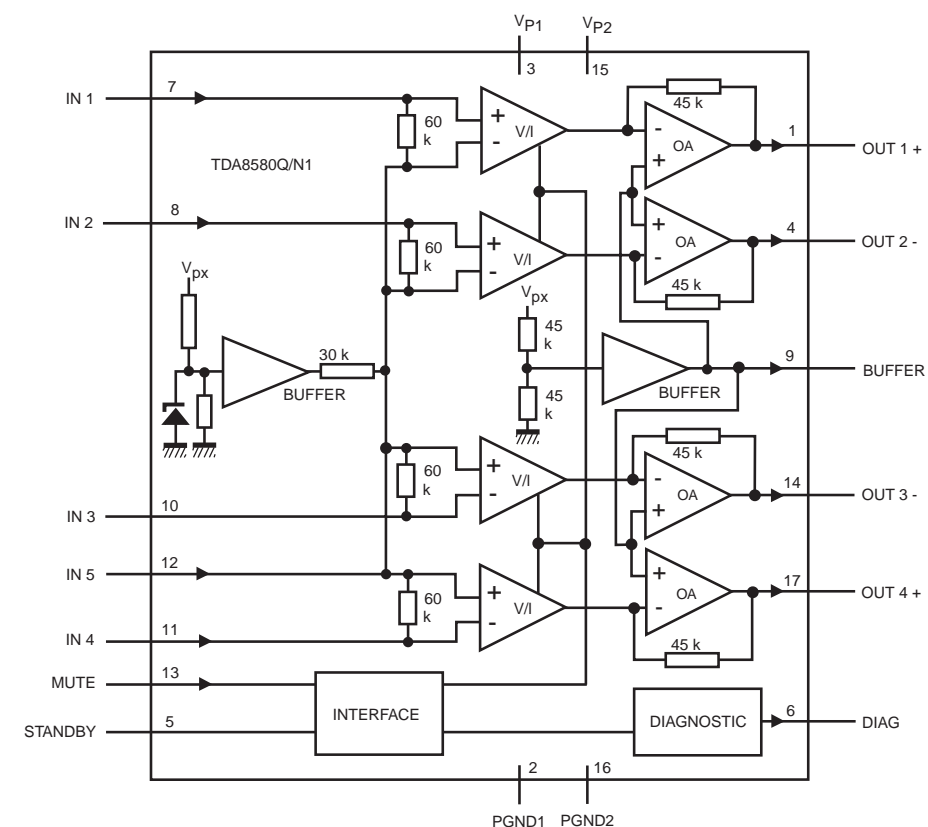

A

[POWER SUPPLY, DEFLECTION, TUNER/IF, AUDIO, MTS]

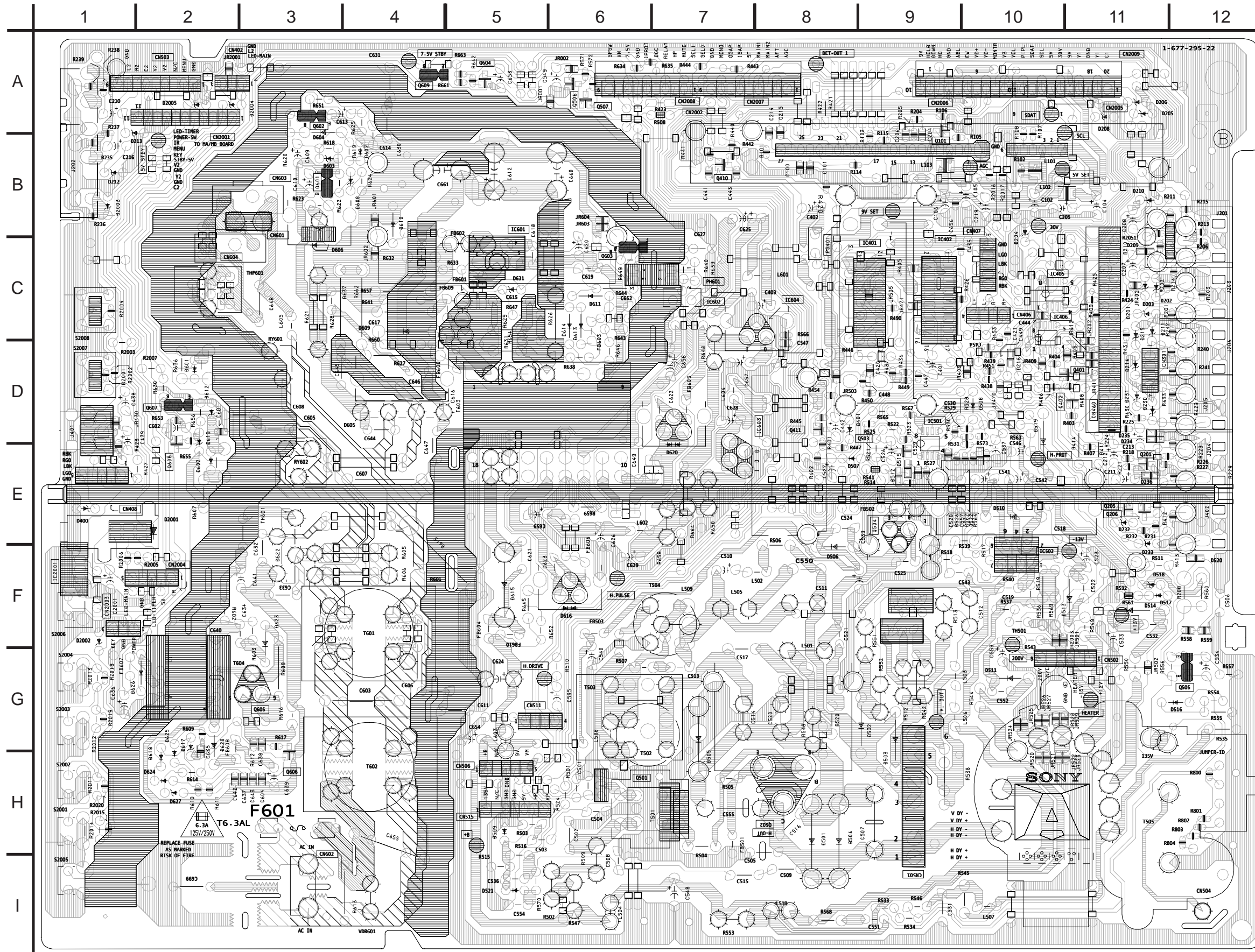

A BOARD LOCATOR LIST

DIODE	D604	B3	TRANSISTOR
D204	B10	D605	D4 Q101 A9
D208	A11	D606	C3 Q410 B7
D209	C11	D607	B4 Q411 D8
D210	B11	D608	B3 Q501 H7
D211	C11	D609	C4 Q502 H7
D212	B1	D610	B4 Q503 D9
D213	B1	D611	C6 Q504 E9
D214	D11	D612	D2 Q505 G12
D215	C11	D613	C6 Q506 A6
D230	D11	D614	C6 Q507 A6
D231	D11	D615	F5 Q601 B3
D232	E11	D616	F6 Q602 A3
D233	E11	D617	H2 Q603 C6
D401	D8	D618	H2 Q604 A5
D501	H8	D619	D2 Q605 G3
D502	G9	D620	D7 Q606 H3
D503	G9	D622	F3 Q607 D2
D504	H8	D623	G2 Q608 D2
D505	G7	D624	G5 Q609 A4
D506	F8	D625	H2
D507	E8	D626	G1
D508	D9	D627	H2
D509	H5	D628	H2
D510	E10	D2001	E2
D511	G10	D2002	F1
D512	E9	D2003	B1
D513	F10	D2004	A2
D514	F11	D2005	A2
D515	E9	IC	
D516	G11	IC401	C9
D517	F11	IC402	B9
D518	F11	IC501	D9
D519	D10	IC502	F10
D520	F12	IC601	B5
D521	I5	IC602	C7
D522	E9	IC603	D7
D601	D2	IC604	C8
D602	E2	IC2001	E1
D603	B3		

A BOARD SCHEMATIC DIAGRAM

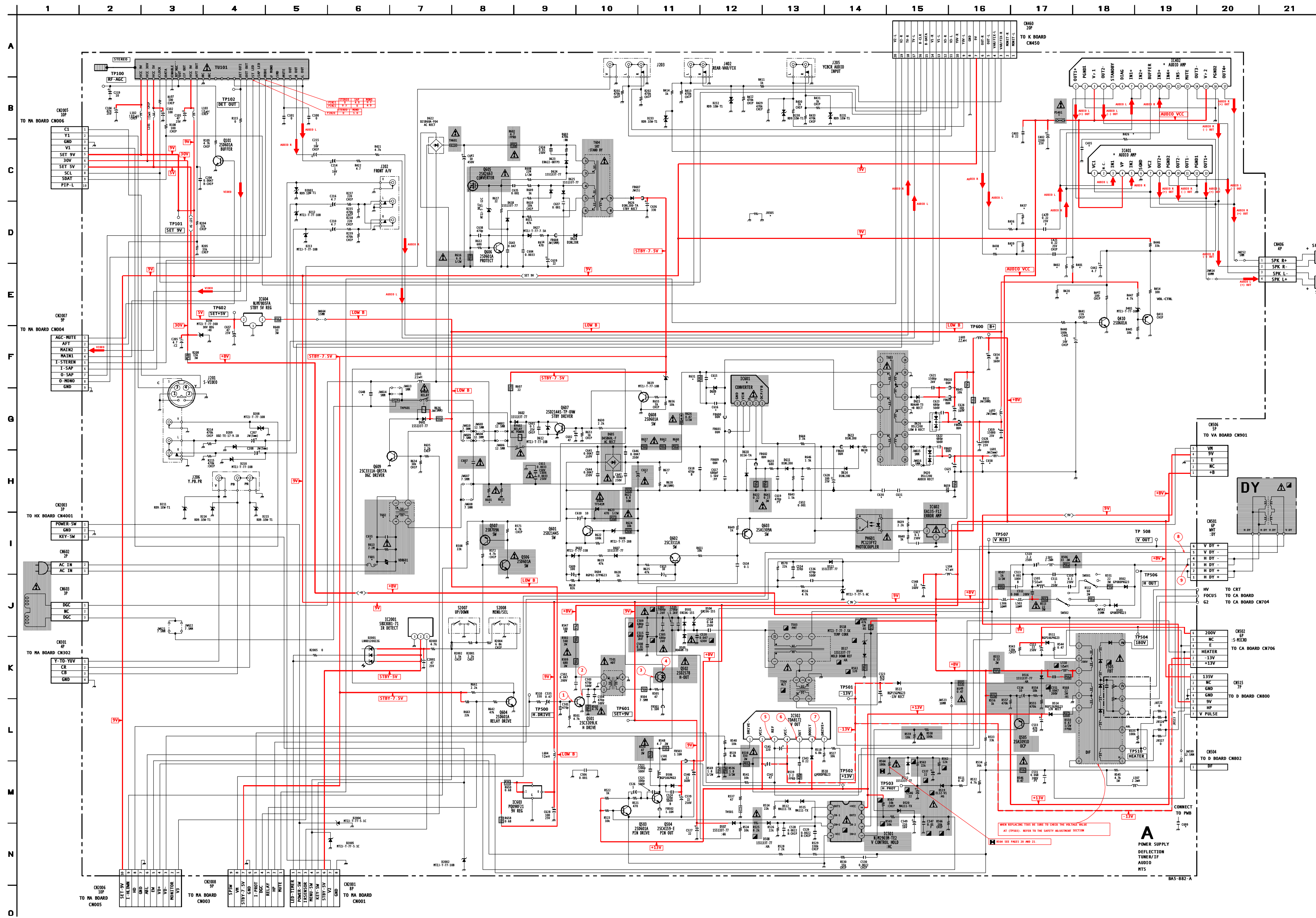

A BOARD MARK (*) LIST

REF NO.	LOC.	KV-27FS12 KV-27FS16	KV-29FS12 KV-29FS12C
C435	B18	#	.22UF 25V
C607	H18	.47UF 125V	.47UF 300V
C612	H11	680UF 250V	560UF 400V
C615	F12	#	.022UF 400V
C616	G12	#	.22UF 25V
C625	H16	1000UF 25V	1500UF 25V
C630	H15	4700 PF 250V	#
C631	H15	4700PF 250V	#
C648	G6	.22UF 125V	.22UF 300V
C655	H7	.47UF 125V	.47UF 300V
C658	I16	1000UF 25V	15000UF 25V
C699	L19	.0047UF 250V	#
D609	G12	#	RU-1P
F601	I6	6.3A/125V	6.3A/250V
IC401	C19	TDA7057 AQ/N2	#
IC402	A19	#	TDA8580Q/N1
IC601	F12	STR-F6626	STR-F6656
JR505	D13	0	#
JW607	H8	#	JW(7.5MM)
JW608	H8	#	JW(7.5MM)
JW609	G8	#	JW(7.5MM)
JW610	G8	#	JW(7.5MM)
PS401	B17	1-576-336-21	1-532-686-21
R401	D18	#	20K
R402	D18	#	10K
R420	E17	3.9K	#
R426	B19	#	22
R436	D14	10K	22K
R437	D15	10K	4.7K
R438	D14	10K	22K
R439	D14	10K	4.7K
R601	H9	4.7M 1/2W	#
R615	H9	#	8.2M
R627	H11	390K	270K
R631	F12	#	100K
R637	G11	JW(20MM)	5.6K
R638	G14	33	56
R660	G11	15K	5.6K
R662	G11	JW(20MM)	5.6K
T602	I6	1-435-617-11	1-426-717-11
T603	F15	1-433-806-11	1-433-807-11
VDR601	I7	1-803-585-11	1-803-967-11

: Not Mounted

A BOARD TRANSISTOR VOLTAGE LIST

Q101		Q502		Q506		Q603		Q608	
pin	volt	pin	volt	pin	volt	pin	volt	pin	volt
B	0.0	B	-0.1	B	0.0	B	-23.6	B	0.0
C	5.6	C	133.0	C	0.0	C	-31.2	C	0.7
E	GND	E	GND	E	GND	E	-23.6	E	GND

Q410		Q503		Q507		Q604		Q609	
pin	volt	pin	volt	pin	volt	pin	volt	pin	volt
B	0.0	B	0.2	B	0.0	B	0.1	B	0.0
C	5.2	C	3.8	C	0.0	C	4.1	C	13.9
E	GND	E	0.0	E	0.0	E	GND	E	GND

Q411		Q504		Q601		Q606	
pin	volt	pin	volt	pin	volt	pin	volt
B	5.3	B	0.1	B	-33.0	B	-36.1
C	GND	C	-6.5	C	-33.0	C	-35.3
E	5.2	E	0.0	E	-33.1	E	-36.3

Q501		Q505		Q602		Q607	
pin	volt	pin	volt	pin	volt	pin	volt
B	0.0	B	134.9	B	-32.8	B	0.7
C	93.3	C	1.8	C	-23.6	C	0.1
E	GND	E	135.5	E	-32.9	E	GND

All voltages are in V

A BOARD TRANSISTOR VOLTAGE LIST

Q605	
pin	volt
D	-35.6
G	40.8
S	36.8

All voltages are in V

A BOARD IC VOLTAGE LIST

IC401		IC402		IC502		IC604		IC602		IC2001		IC603		IC601		TU101	
pin	volt	pin	volt	pin	volt	pin	volt	pin	volt	pin	volt	pin	volt	pin	volt	pin	volt
1	0.6	1	6.8	1	14.1	1	13.3	1	5.0	1	8.9	1	5.0	1	13.3	1	N/C
2	0.0	2	1.8	2	14.1	2	-32.7	2	5.0	2	9.9	2	5.0	2	8.9	2	N/C
3	2.4	3	GND	3	GND	3	-23.8	3	5.0	3	8.9	3	5.0	3	8.9	3	N/C
4	14.3	4	14.1	4	6.8	4	14.0	4	5.0	4	8.9	4	5.0	4	8.9	4	N/C
5	2.4	5	6.8	5	-12.6	5	135.9	5	5.0	5	8.9	5	5.0	5	8.9	5	N/C
6	0.0	6	4.3	6	1.0	6	-13.9	6	5.0	6	8.9	6	5.0	6	8.9	6	N/C
7	0.6	7	NC	7	0.2	7	0.2	7	5.0	7	8.9	7	5.0	7	8.9	7	N/C
8	6.9	8	4.1	8	3.7	8	14.3	8	5.0	8	8.9	8	5.0	8	8.9	8	N/C
9	0.0	9	4.1	9	2.5	9	2.1	9	5.0	9	8.9	9	5.0	9	8.9	9	N/C
10	6.9	10	6.8	10	GND	10	GND	10	5.0	10	8.9	10	5.0	10	8.9	10	N/C
11	6.9	11	4.1	11	9.5	11	pin	11	13.3	11	8.9	11	5.0	11	8.9	11	N/C
12	0.0	12	4.1	12	6	10.1	1	-31.8	12	8.6	12	5.0	12	8.6	12	N/C	

All voltages are in V

A BOARD WAVEFORMS

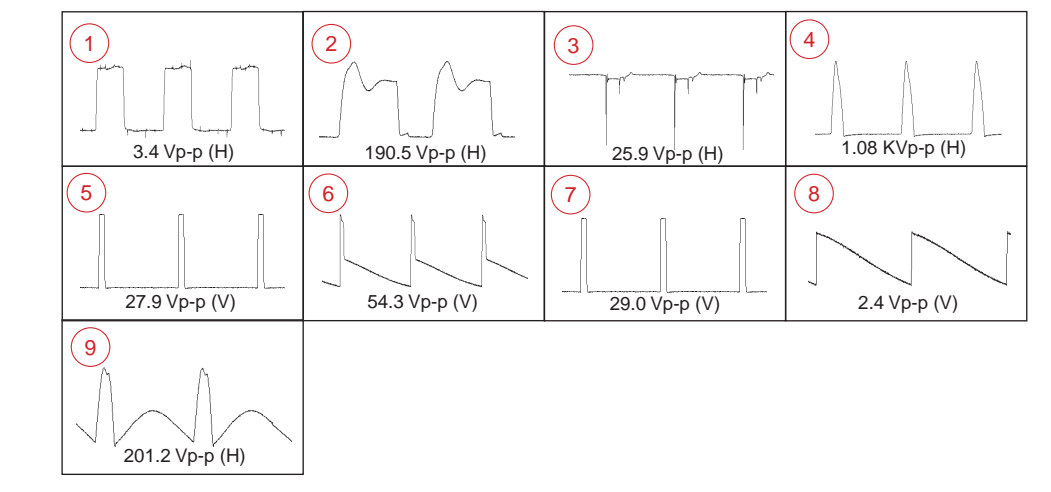

MA BOARD SCHEMATIC DIAGRAM

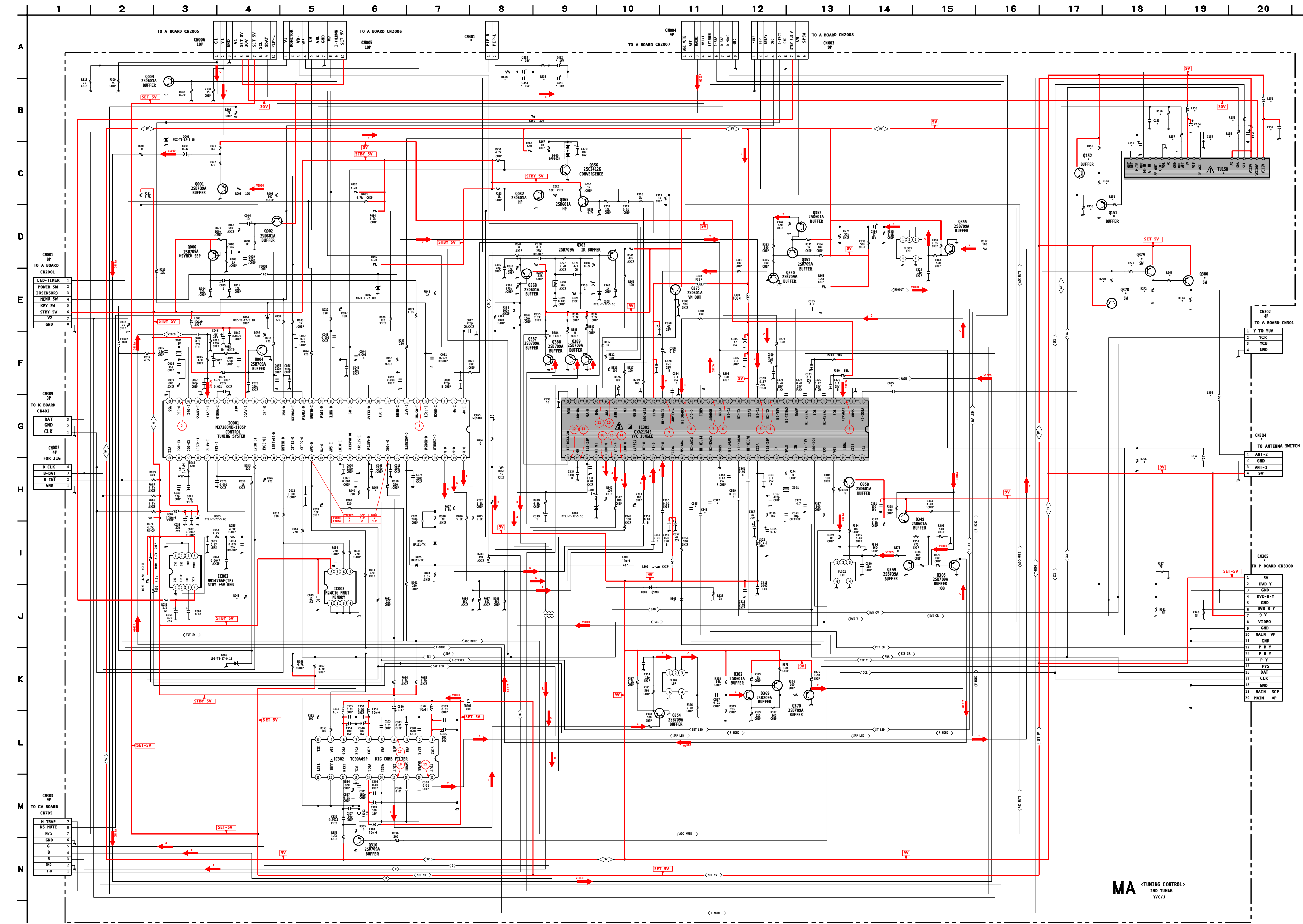

MA BOARD MARK (*) LIST

REF NO.	LOC.	KV-27FS12 KV-29FS12 KV-29FS12C	KV-27FS16
C005	F14	#	.47 UF 25V
C151	C18	#	1UF
C153	B18	#	.0047UF
C154	B19	#	47UF
C155	B19	#	10UF
C156	B20	#	47UF 25V
C157	B20	#	100UF
C345	H11	#	.01UF
C346	H11	#	.01UF
C347	H11	#	.01UF
C451	B9	#	1UF 16V
C452	A9	#	1UF 16V
C453	A9	#	1UF 16V
C454	B8	#	1UF 16V
CN304	G20	#	1-564-507-11
CN305	I20	#	1-573-298-21
CN401	A8	#	1-564-505-11
D303	J11	#	1SS133T-77
L150	B19	#	10UH
L151	B20	#	100UH
L356	G19	#	JW(5MM)
L357	H19	#	JW(5MM)
Q151	D18	#	2SB709A-QRS-TX
Q152	C17	#	2SD601A-QRS-TX
Q378	E18	#	2SB709A-QRS-TX
Q379	E18	#	2SA1309A-QRSTA
Q380	E19	#	2SB709A-QRS-TX
R048	J4	#	100
R069	H6	#	220
R150	D17	#	1.5K
R151	D18	#	100
R154	C17	#	560
R155	C17	#	560
R156	B19	#	33K
R157	B19	#	22K
R158	B20	#	100
R159	B20	#	100
R264	E19	#	22K
R266	H18	#	22K
R270	E18	#	22K
R271	D18	#	22K
R272	E18	#	22K
R314	E19	#	22K
R434	A8	#	4.7K
R435	A9	#	4.7K
TU150	C18	#	FSS BTF-FA402

: Not Mounted

MA BOARD WAVEFORMS

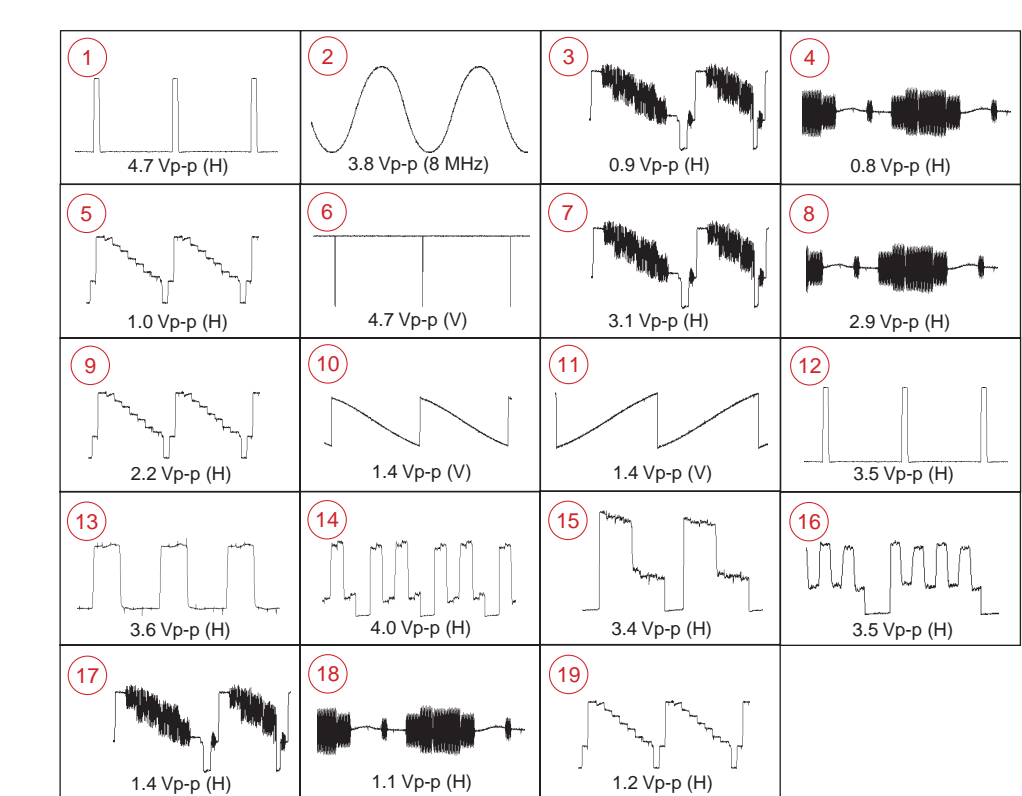

MA BOARD TRANSISTOR VOLTAGE LIST

Q001		Q082		Q305		Q352		Q359		Q375		Q388			
pin	volt	pin	volt	pin	volt	pin	volt	pin	volt	pin	volt	pin	volt		
B	5.0	B	0.6	B	4.4	B	2.5	B	2.1	B	5.0	B	1.9		
C	GND	C	0.5	C	GND	C	7.8	C	GND	C	0.0	C	GND		
E	5.6	E	GND	E	5.0	E	1.9	E	2.7	E	4.4	E	2.5		
Q002		Q151		Q310		Q354		Q365		Q378		Q389			
pin	volt	pin	volt	pin	volt	pin	volt	pin	volt	pin	volt	pin	volt	pin	volt
B	4.4	B	4.0	B	4.8	B	2.5	B	0.5	B	4.3	B	2.0		
C	9.0	C	GND	C	GND	C	GND	C	3.8	C	4.9	C	GND		
E	3.8	E	4.6	E	5.4	E	3.2	E	0.0	E	5.1	E	2.6		
Q003		Q152		Q349		Q355		Q368		Q379					
pin	volt	pin	volt	pin	volt	pin	volt	pin	volt	pin	volt	pin	volt	pin	volt
B	0.6	B	6.8	B	4.4	B	0.0	B	2.4	B	4.4				
C	0.0	C	9.0	C	9.0	C	GND	C	9.0	C	5.1				
E	GND	E	6.2	E	3.8	E	3.0	E	2.4	E	5.1				
Q004		Q302		Q350		Q356		Q369		Q380					
pin	volt	pin	volt	pin	volt	pin	volt	pin	volt	pin	volt	pin	volt	pin	volt
B	4.9	B	2.5	B	4.0	B	0.5	B	7.6	B	5.1				
C	GND	C	7.6	C	GND	C	1.3	C	5.8	C	0.0				
E	3.9	E	1.9	E	4.7	E	GND	E	8.3	E	5.1				
Q006		Q303		Q351		Q358		Q370		Q387					
pin	volt	pin	volt	pin	volt	pin	volt	pin	volt	pin	volt	pin	volt	pin	volt
B	5.2	B	3.6	B	7.8	B	2.4	B	5.8	B	1.9				
C	0.7	C	0.1	C	4.0	C	8.9	C	GND	C	GND				
E	5.0	E	3.5	E	8.4	E	1.8	E	6.4	E	2.5				

All voltages are in V

MA

[TUNING CONTROL, 2ND TUNER, Y/C/J]

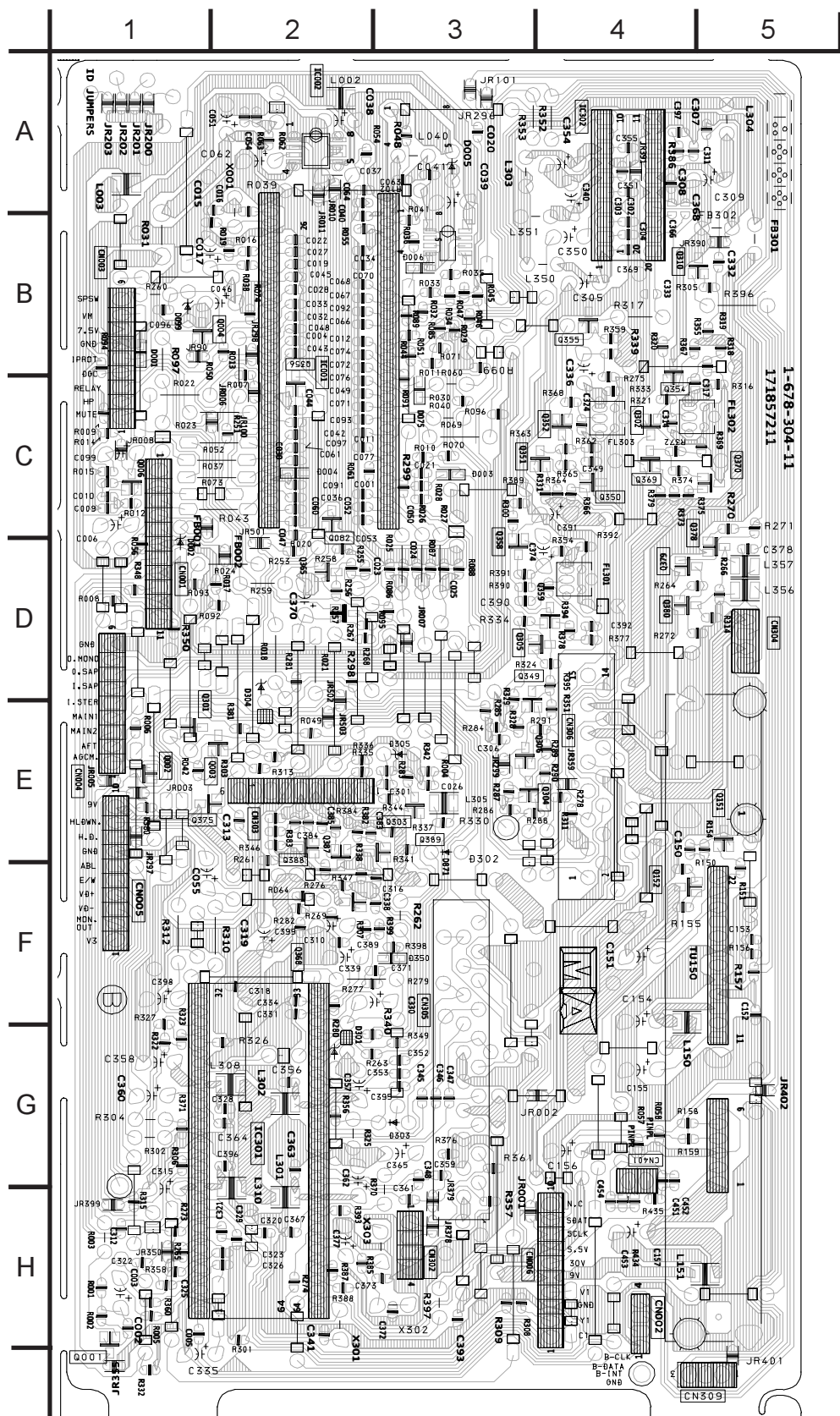

MA BOARD IC VOLTAGE LIST

IC001								IC003								IC302							
pin	volt	19	4.3	38	5.0	57	NC	pin	volt	9	4.8	28	3.5	47	5.2	pin	volt	19	3.2	15	GND		
1	0.5	20	0.1	39	NC	58	0.1	1	GND	10	1.7	29	3.5	48	5.2	1	5.0	20	2.4	17	GND		
2	4.8	21	NC	40	NC	59	NC	2	GND	11	0.0	30	5.9	49	GND	2	1.4	TU101					
3	NC	22	5.0	41	NC	60	NC	3	GND	12	4.8	31	5.5	50	4.8	3	3.2	pin	volt	18	NC		
4	5.0	23	NC	42	4.8	61	0.1	4	GND	13	8.9	32	7.6	51	5.2	4	2.4	1	9.0	20	2.0		
5	0.0	24	5.0	43	4.8	62	0.1	5	4.8	14	NC	33	3.6	52	5.2	5	1.9	2	3.0	21	0.3		
6	0.0	25	2.1	44	NC	63	0.1	6	4.8	15	NC	34	2.3	53	9.0	6	5.0	3	5.0	22	4.0		
7	2.4	26	NC	45	4.8	64	0.1	7	GND	16	4.8	35	2.3	54	5.3	All voltages are in V							
8	4.4	27	0.3	46	NC	IC002								8	5.0	5	4.8						
9	NC	28	2.2	47	4.8	IC301								9	4.8	6	5.1						
10	NC	29	GND	48	0.1	pin	volt	18	GND	37	1.9	56	1.7	10	4.8	7	NC						
11	0.1	30	2.2	49	0.1	1	5.0	1	5.9	20	6.4	39	2.0	11	0.0	8	NC						
12	NC	31	2.3	50	5.0	2	4.9	2	GND	21	3.9	40	0.0	12	0.0	9	NC						
13	0.5	32	GND	51	5.0	3	7.2	3	5.2	22	5.6	41	4.6	13	2.6	10	NC						
14	NC	33	5.0	52	NC	4	5.0	4	5.0	23	8.9	42	4.6	14	2.1	11	7.5						
15	0.1	34	2.5	53	1.0	5	GND	5	4.8	24	5.7	43	4.6	15	5.0	12	NC						
16	0.1	35	2.5	54	0.1	6	GND	6	5.0	25	GND	44	8.9	16	0.0	13	9.0						
17	0.0	36	5.0	55	NC	7	NC	7	4.8	26	3.5	45	0.2	17	2.5	14	5.3						

MA BOARD IC BLOCK DIAGRAMS

MA BOARD: IC301 CXA2154S

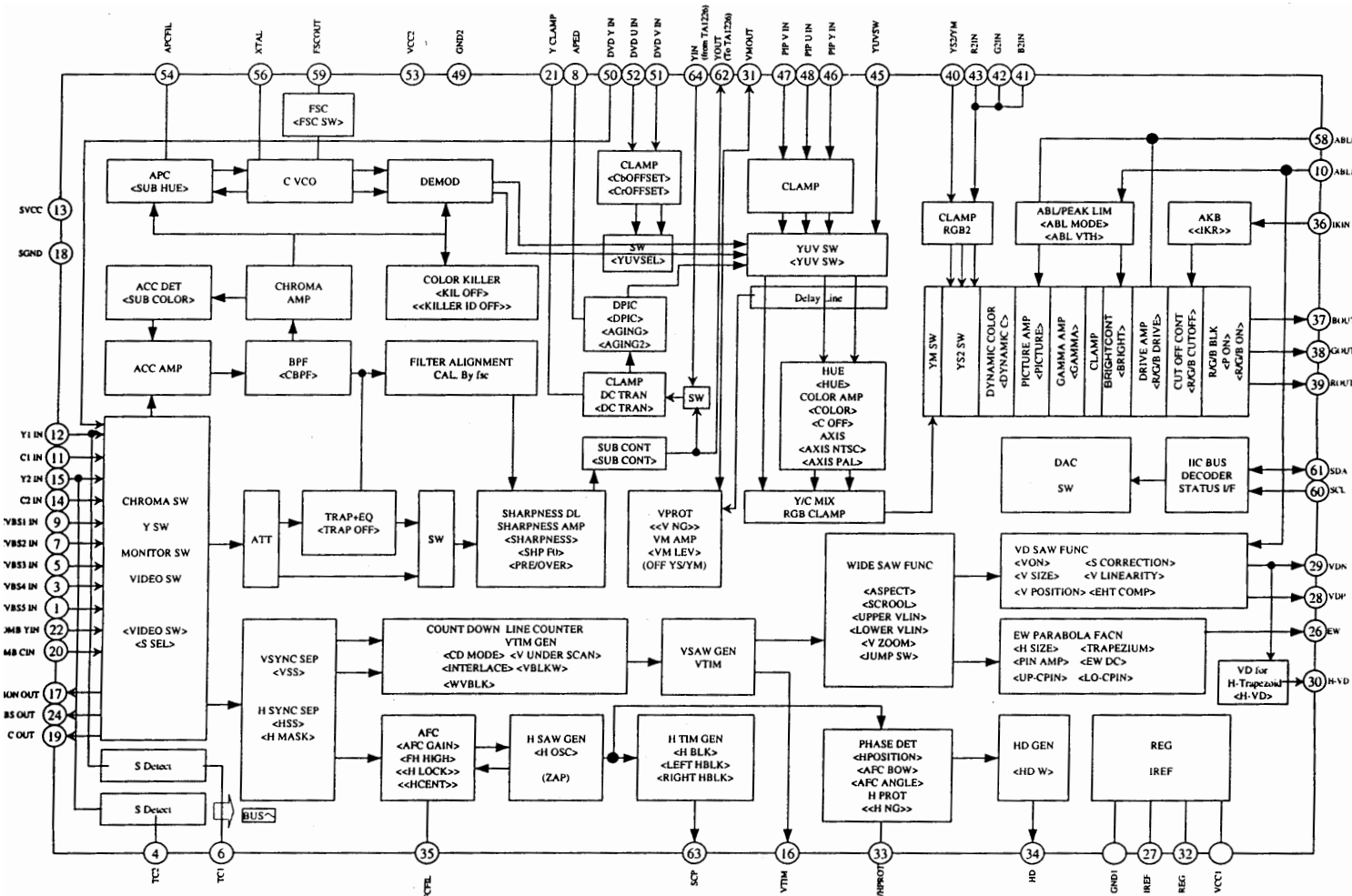

MA BOARD LOCATOR LIST

DIODE	D005	A-3	D305	E-2	IC003	B-3	Q002	E-1	Q151	E5	Q310	B-4	Q354	C-4	Q365	D-2	Q378	C4	Q389	E-3	
D001	B-1	D006	B-3	D360	D-2	IC301	G-2	Q003	E-1	Q152	F4	Q349	D-3	Q355	B-4	Q368	F-2	Q379	D4	CRYSTAL	
D002	C-1	D075	C-3		IC	IC302	A-4	Q004	B-1	Q302	C-4	Q350	C-4	Q356	C-2	Q369	C-4	Q380	D4	X001	A-2
D003	C-3	D301	F-2	IC001	B-2	TRANSISTOR	Q006	C-1	Q303	E-2	Q351	C-3	Q358	D-3	Q370	C-4	Q387	E-2	X301	H-2	
D004	C-2	D303	G3	IC002	A-2	Q001	H-1	Q082	C-2	Q305	D-3	Q352	C-3	Q359	D-3	Q375	E-2	Q388	E-2		

CA BOARD SCHEMATIC DIAGRAM

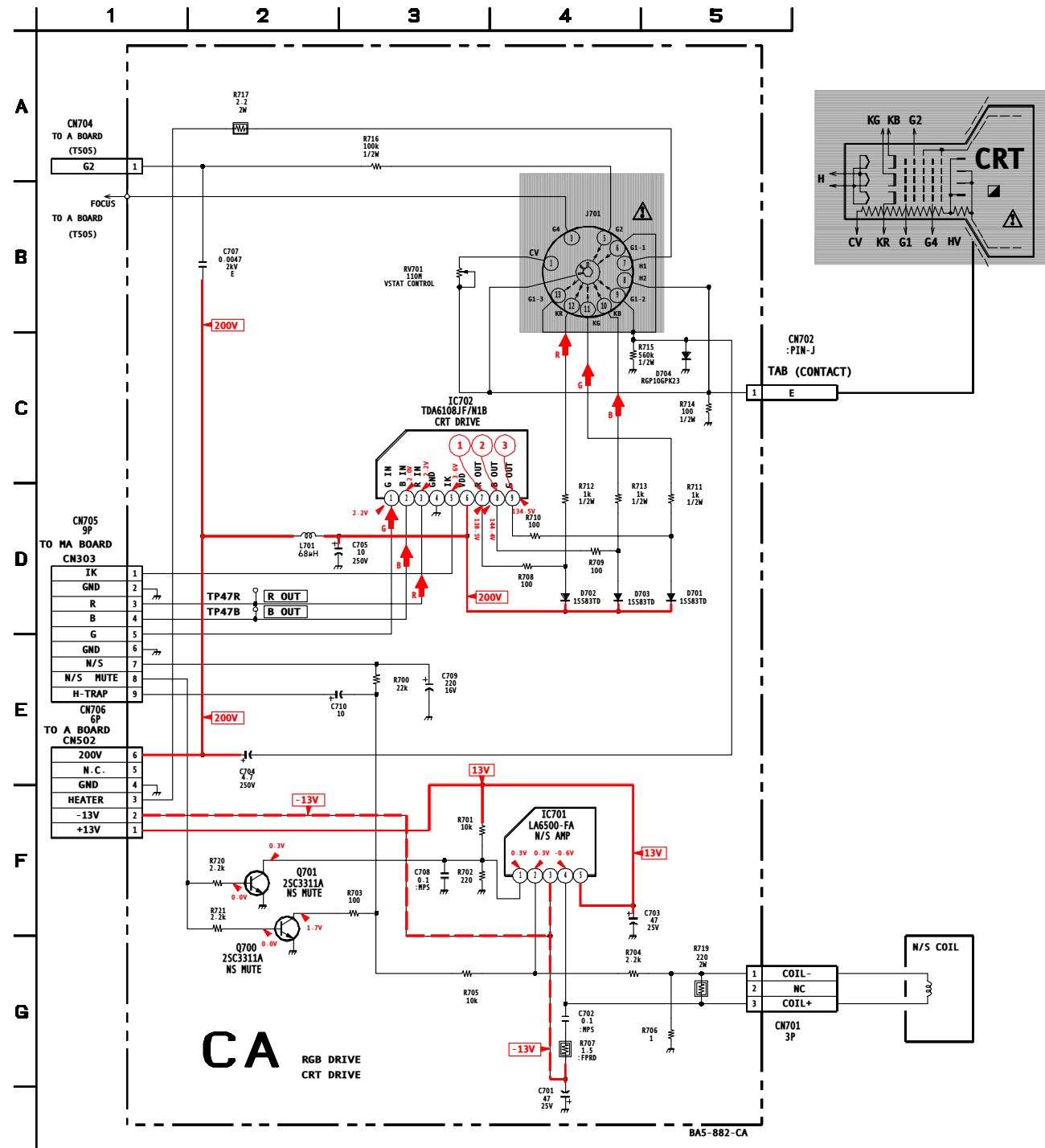

CA [RGB DRIVE, CRT DRIVE]

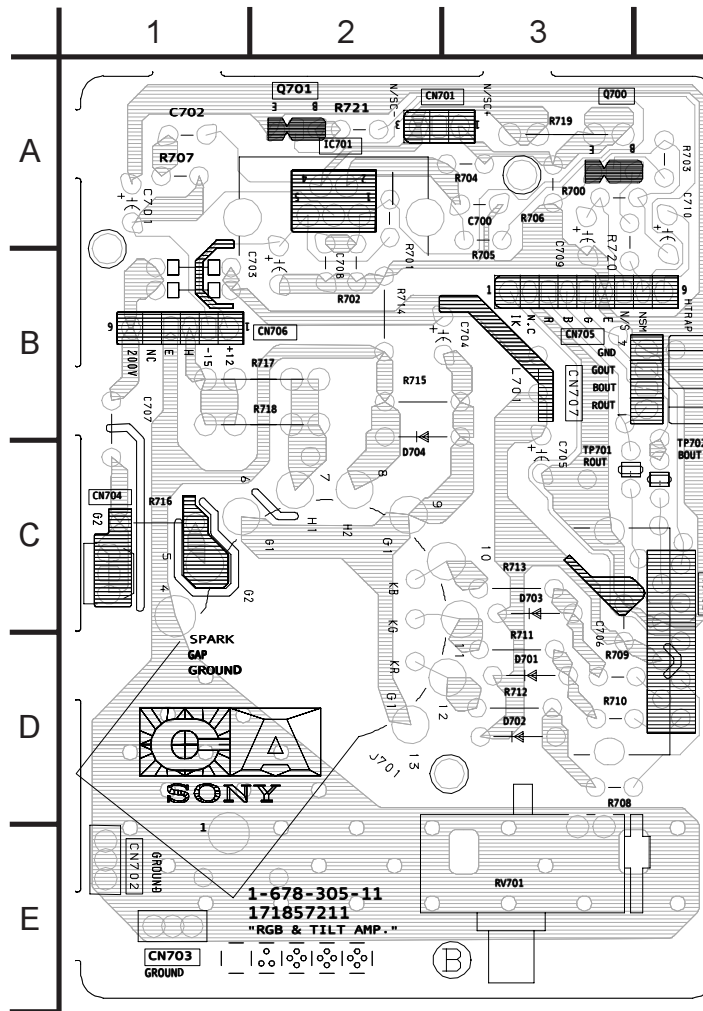

CA BOARD WAVEFORMS

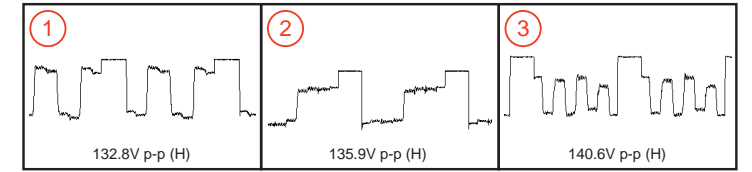

HX BOARD SCHEMATIC DIAGRAM

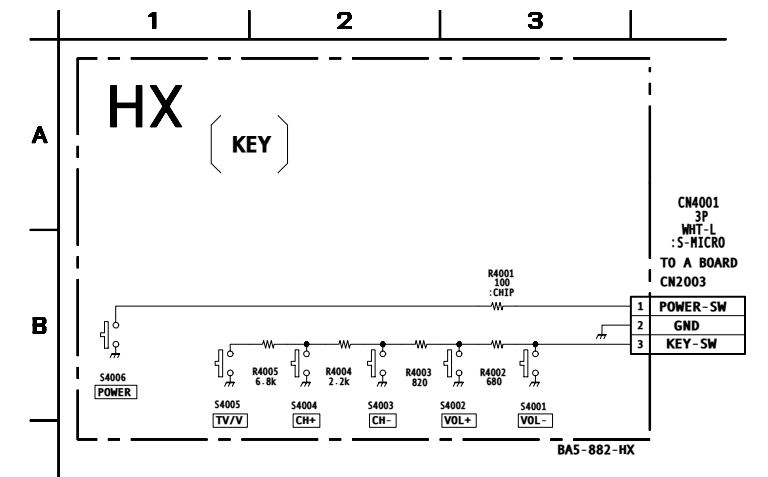

HX [KEY]

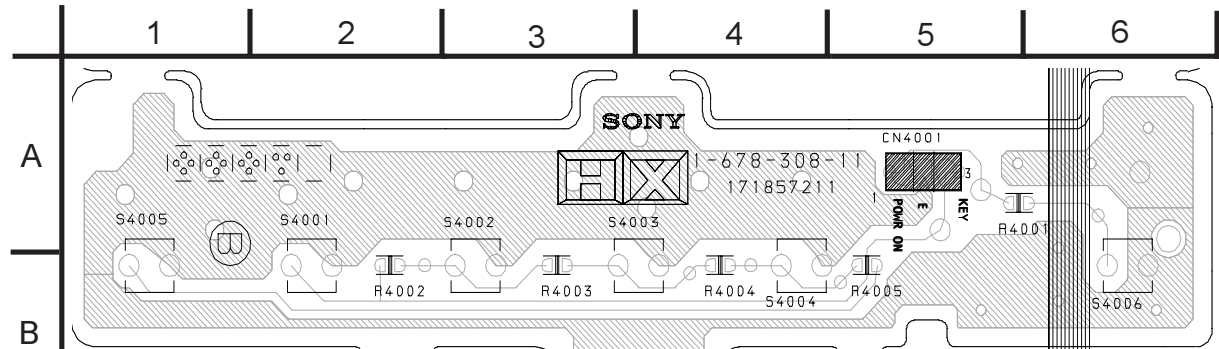

D BOARD SCHEMATIC DIAGRAM

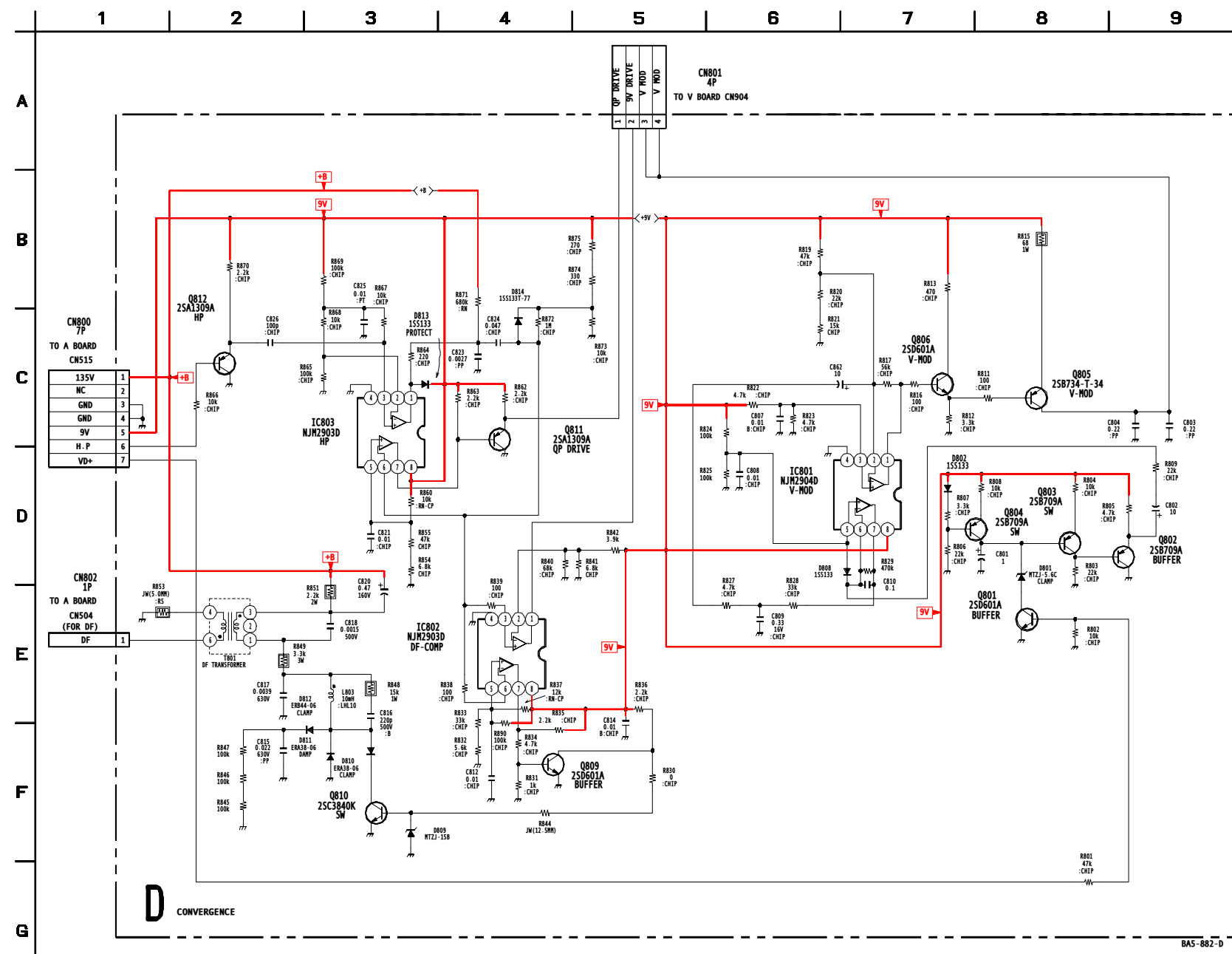

D [CONVERGENCE]

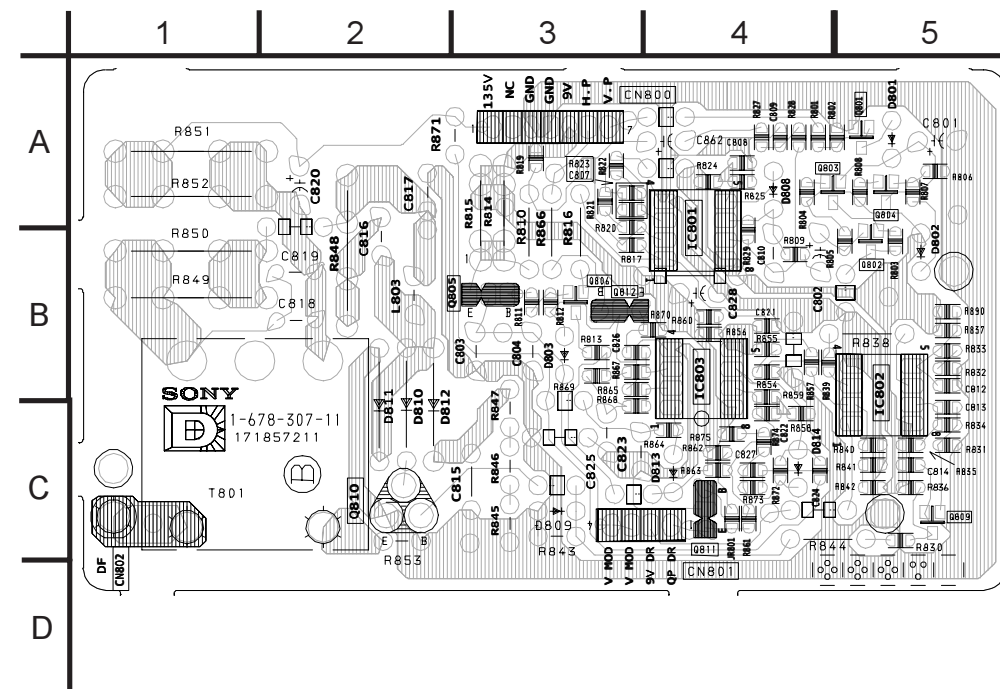

D BOARD TRANSISTOR VOLTAGE LIST

Q801		Q806	
pin	volt	pin	volt
B	-2.2	B	7.3
C	3.4	C	8.1
E	GND	E	6.7
Q802		Q809	
pin	volt	pin	volt
B	4.3	B	0.3
C	GND	C	0.3
E	4.9	E	GND
Q803		Q810	
pin	volt	pin	volt
B	6.4	B	0.3
C	4.3	C	1.2
E	7.0	E	GND
Q804		Q811	
pin	volt	pin	volt
B	7.4	B	6.3
C	6.4	C	GND
E	7.9	E	6.4
Q805		Q812	
pin	volt	pin	volt
B	6.7	B	0.0
C	0.6	C	GND
E	7.3	E	0.6

D BOARD IC VOLTAGE LIST

IC801		IC803	
pin	volt	pin	volt
1	7.3	1	2.3
2	4.4	2	4.3
3	4.5	3	4.7
4	GND	4	GND
5	4.5	5	7.6
6	4.5	6	6.7
7	4.5	7	6.0
8	9.0	8	9.0
IC802			
pin	volt		
1	6.8		
2	5.7		
3	0.0		
4	GND		
5	6.8		
6	6.7		
7	3.2		
8	9.0		

All voltages are in V

All voltages are in V

K BOARD SCHEMATIC DIAGRAM

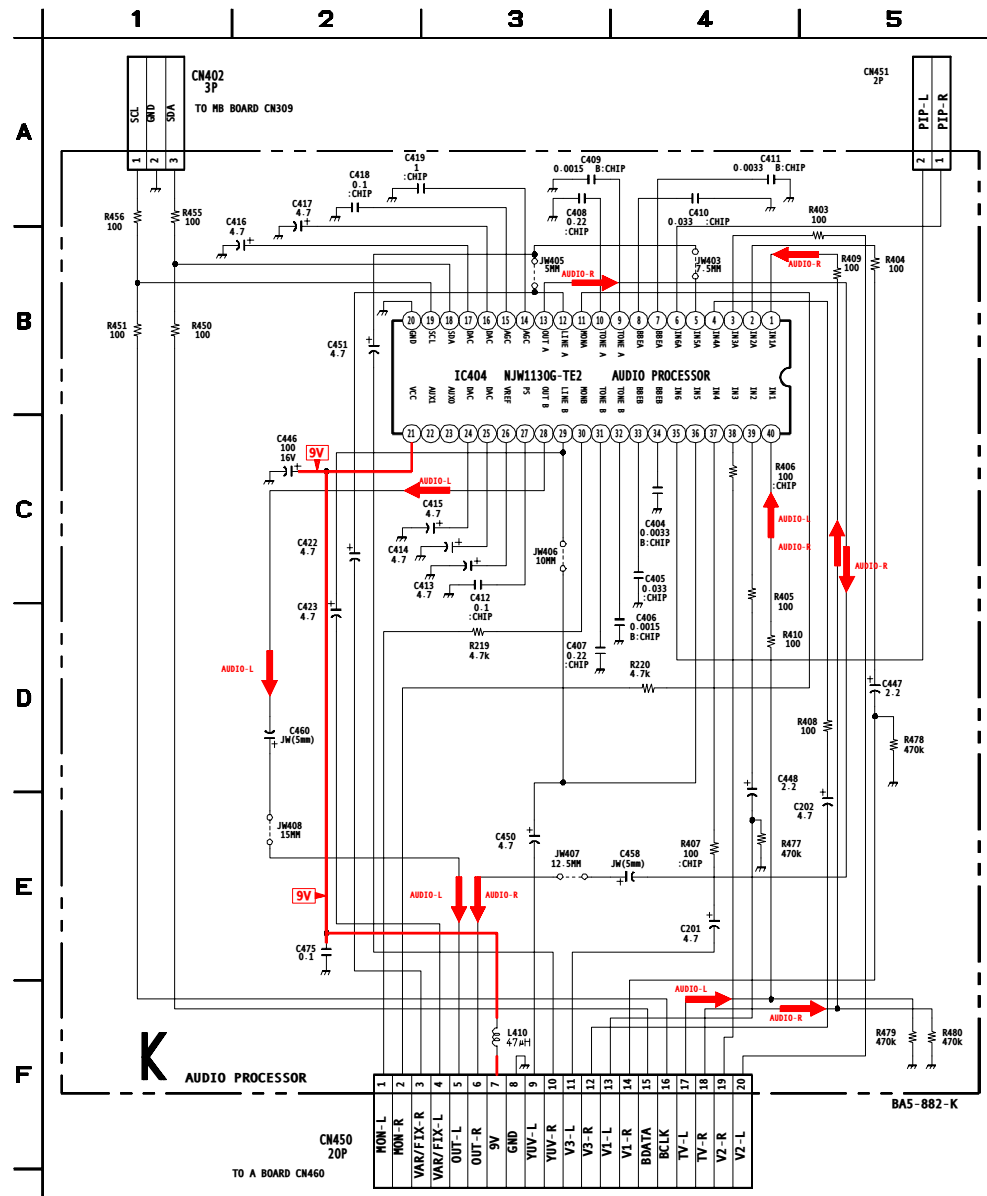

K [AUDIO PROCESSOR]

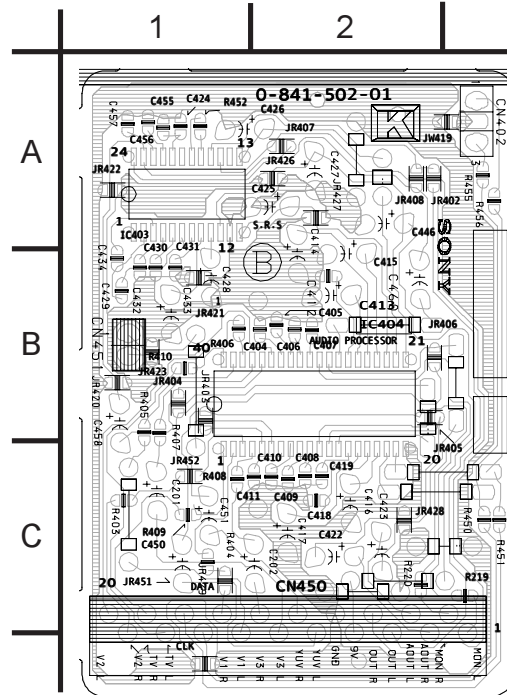

VA [VELOCITY MODULATOR]

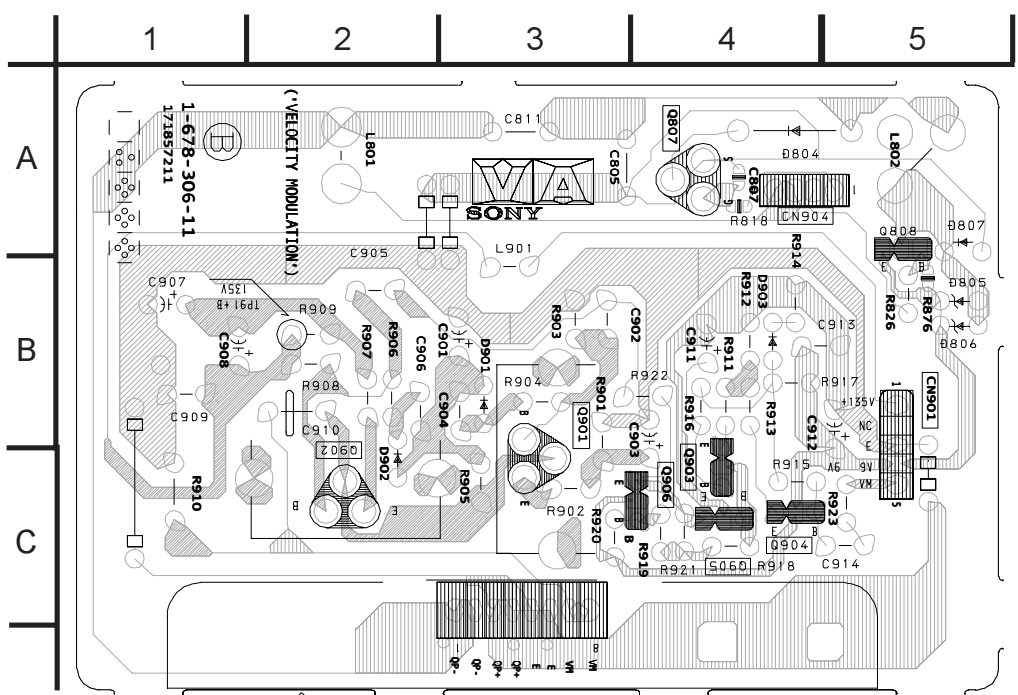

VA BOARD SCHEMATIC DIAGRAM

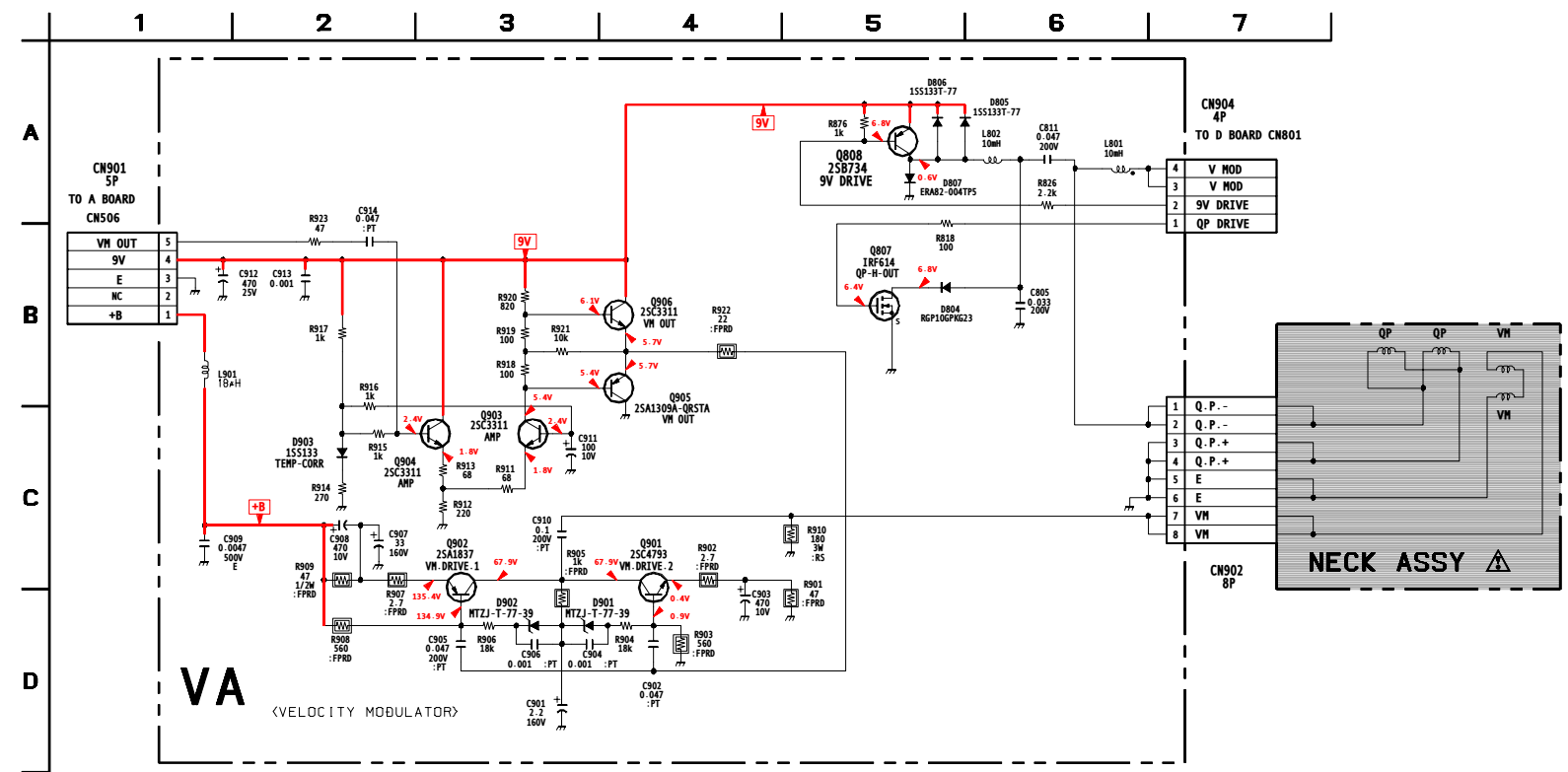

K BOARD IC VOLTAGES

IC404	6	NC	13	4.5	20	GND	27	3.9	34	4.5	
pin	volt	7	4.7	14	1.0	21	8.9	28	4.5	35	NC
1	4.5	8	4.5	15	4.5	22	NC	29	4.5	36	4.5
2	4.5	9	4.5	16	0.9	23	NC	30	4.5	37	4.5
3	4.5	10	4.5	17	0.9	24	1.3	31	4.5	38	4.5
4	4.5	11	4.5	18	4.8	25	1.3	32	4.5	39	4.5
5	4.5	12	4.5	19	4.9	26	4.4	33	4.5	40	4.5

All voltages are in V

P BOARD SCHEMATIC DIAGRAM

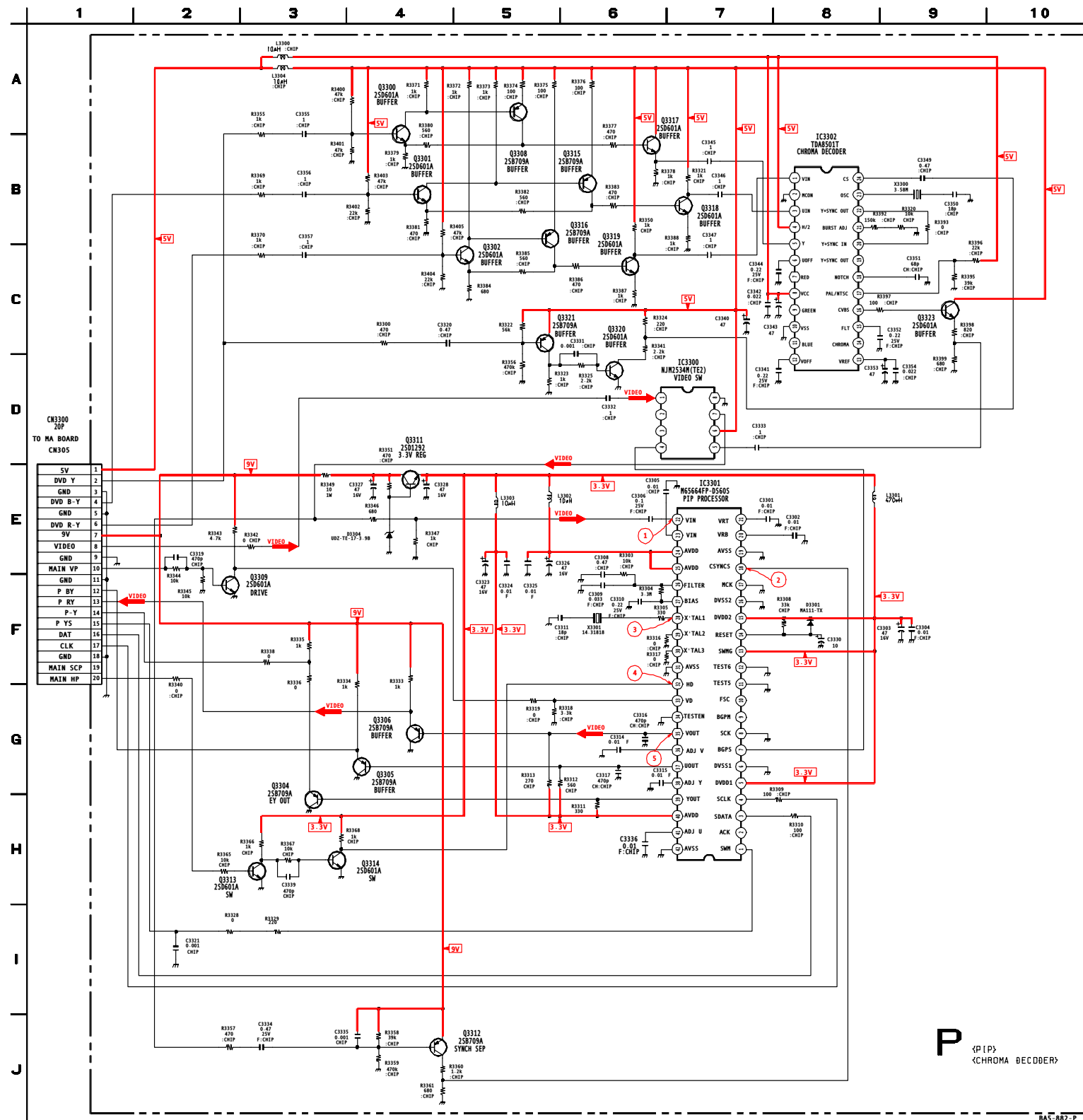

P [PIP, CHROMA DECODER]

COMPONENT SIDE

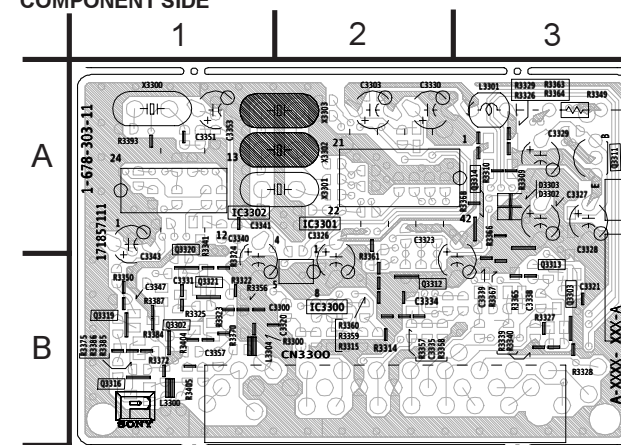

CONDUCTOR SIDE

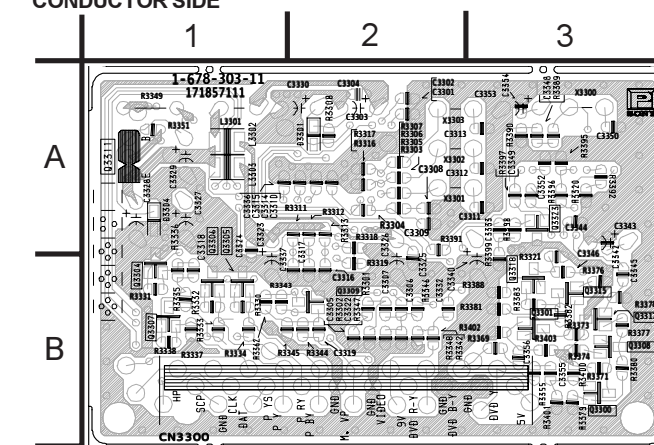

P BOARD IC VOLTAGE LIST

IC3300	29	0.0	
pin	volt	30	0.0
1	2.6	31	0.0
2	0.0	32	0.5
3	2.6	33	0.0
4	0.0	34	0.0
5	2.6	35	3.1
6	5.0	36	1.1
7	1.8	37	3.0
8	0.0	38	1.2
IC3301	39	2.6	
pin	volt	40	3.5
1	0.2	41	1.0
2	0.0	42	0.0
3	4.7		
IC3302	pin	volt	
4	4.8	1	0.0
5	3.2	2	0.0
6	0.0	3	0.0
7	0.0	4	5.0
8	0.0	5	0.3
9	0.0	6	2.0
10	0.8	7	0.9
11	0.0	8	5.1
12	0.0	9	0.9
13	3.2	10	0.0
14	3.2	11	0.9
15	3.2	12	2.0
16	0	13	2.5
17	0	14	2.5
18	0.3	15	0.8
19	0.0	16	1.7
20	0.5	17	3.3
21	1.6	18	1.7
22	1.0	19	0.0
23	0.6	20	1.7
24	3.4	21	2.5
25	3.4	22	1.7
26	1.4	23	1.3
27	1.7	24	1.7
28	2.0		

All voltages are in V

P BOARD TRANSISTOR VOLTAGE LIST

Q3300	Q3305	Q3311	Q3315	Q3319					
pin	volt	pin	volt	pin	volt				
B	2.4	B	3.0	B	4.1	B	4.2	B	1.9
C	4.2	C	0.0	C	7.7	C	2.4	C	3.8
E	1.8	E	3.7	E	3.5	E	4.8	E	1.3
Q3301	Q3306	Q3312	Q3316	Q3320					
pin	volt	pin	volt	pin	volt				
B	1.6	B	3.1	B	8.8	B	0.0	B	0.0
C	4.2	C	0.0	C	0.7	C	1.9	C	5.0
E	1.0	E	3.8	E	9.0	E	4.9	E	0.0
Q3302	Q3308	Q3313	Q3317	Q3321					
pin	volt	pin	volt	pin	volt				
B	1.6	B	4.2	B	0.2	B	2.9	B	4.7
C	4.3	C	2.9	C	2.7	C	5.0	C	0.0
E	1.0	E	4.9	E	0.0	E	2.3	E	5.0
Q3304	Q3309	Q3314	Q3318	Q3323					
pin	volt	pin	volt	pin	volt				
B	2.6	B	0.7	B	0.5	B	2.4	B	1.8
C	0.0	C	0.0	C	0.6	C	3.3	C	5.0
E	3.3	E	0.0	E	0.0	E	1.8	E	1.1

All voltages are in V

P BOARD WAVEFORMS

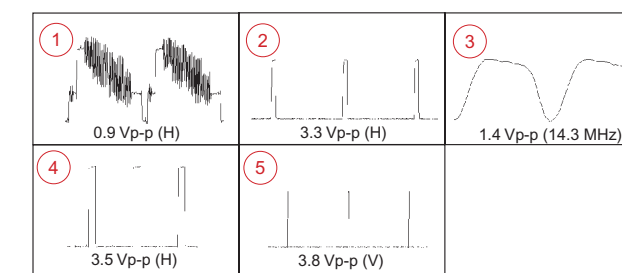

6-4. SEMICONDUCTORS

2SA1037AK-7146-QR
2SB709A-QRS-TX
2SD601A-QRS-TX
2SC2412K-T-146-QR

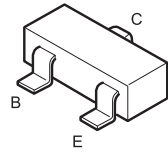

2SB734-7-34
2SC3209LK-TP

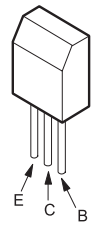

2SC1740S-QRT

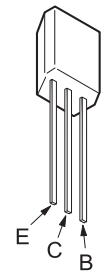

2SA1309A-QRSTA
2SC3311A-QRSTA
2SD2144S-TP-UVW

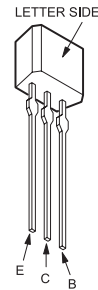

2SC3840K

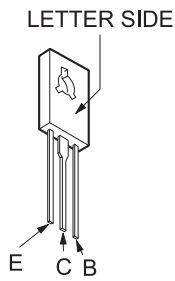

2SA1837
2SC4159-E

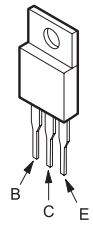

2SA1091O-TPE2
2SA993AS-QRT

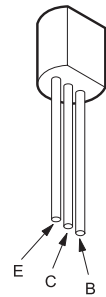

2SK2845-LB102

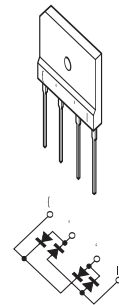

TF541M

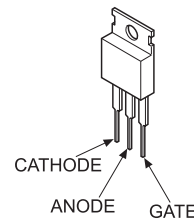

IRF614

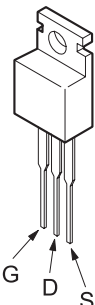

ERA38-06TP1
ERA82-004TP5
1SS133T-77
D1N2OR-TA
D1NS4-TA
MTZJ-T-7712C
MTZJ-T-77-33B
MTZJ-T-77-39

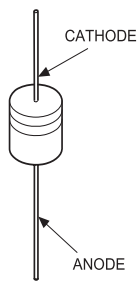

RU-1P
ERC06-15S
MTZJ-T-77-5.1C
MTZJ-T-775.6C
MTZJ-T-77-7.5A
MTZJ-T-77-10B
MTZJ-T-7730D
RD10ES-T1B
RGP10-GPKG3
RGP02-17PKG23

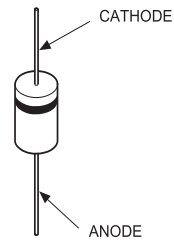

ERB44-06TP1
1SS83TD
D1NL2OU-TA
EL1Z-V1
ERA22-08TP3
GP08DPKG23
RGP10GPKG23
RU4AM-T3

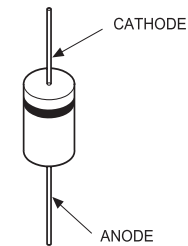

RD9.1EW-T1

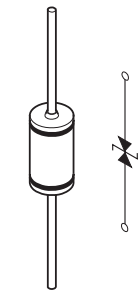

MA111-TX

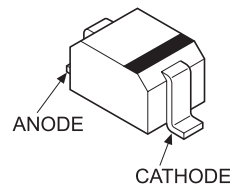

D2SB60A-F04

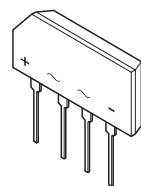

DAP202K-T-146

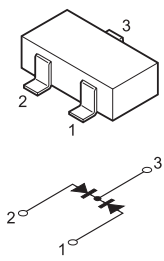

D4SB60L-F

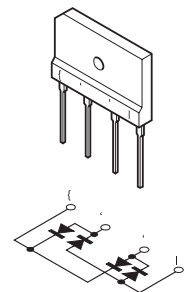

D5LC20U

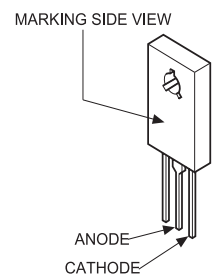

SECTION 7
EXPLODED VIEW

- Items with no part number and no description are not stocked because they are seldom required for routine service.
- The component parts of an assembly are indicated by the reference numbers in the remarks column.
- Items marked * are not stocked since they are seldom required for routine service. Some delay should be anticipated when ordering these items.

Note:

The components identified by shading and mark Δ are critical for safety. Replace only with part number specified.

Note:

Les composants identifiés par un trame et une marque Δ sont critiques pour la sécurité. Ne les remplacer que par une pièce portant le numéro spécifié.

7-1. CHASSIS (KV-29FS12/29FS12C ONLY)

- 7-685-648-79 SCREW +BVTP 3X12
- 7-685-663-79 SCREW +BVTP 4X16
- ▲ 4-046-765-12 SCREW (7) TAPPING

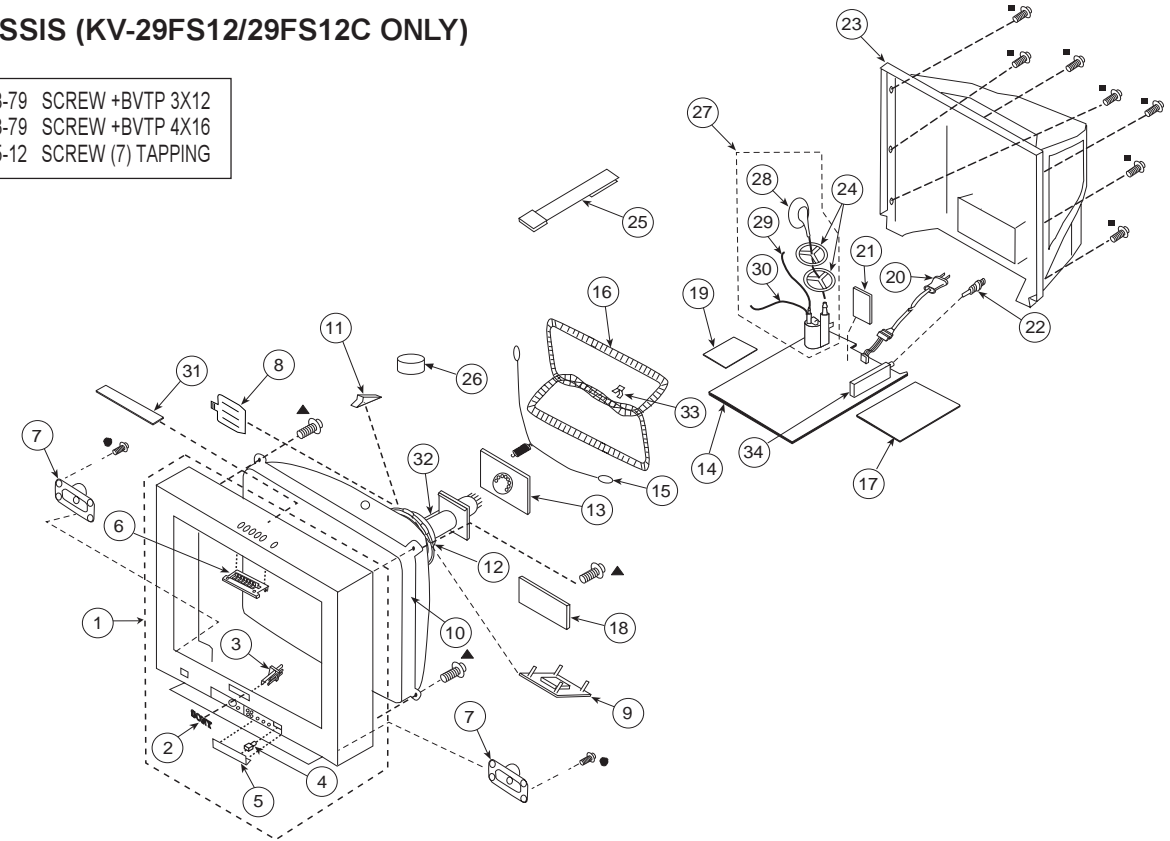

REF. NO.	PART NO.	DESCRIPTION	REMARK	REF. NO.	PART NO.	DESCRIPTION	REMARK
1	X-4037-663-1	BEZNET ASSY	2-5	17	A-1304-200-A	MA (VAR) MOUNTED PC BOARD	
2	3-704-179-31	EMBLEM (NO.9), SONY		18	A-1342-550-A	VA (VAR) MOUNTED PC BOARD	
3	4-075-657-01	GUIDE, LED		19	A-1343-875-A	D (VAR) MOUNTED PC BOARD	
4	4-047-464-01	CATCHER, PUSH		20	Δ 1-769-796-31	CORD, POWER (WITH CONNECTOR) (KV-29F12C ONLY)	
5	4-075-658-01	DOOR		20	Δ 1-790-315-21	CORD, AC POWER (WITH CONNECTOR) (KV-29FS12 ONLY)	
6	4-068-982-02	MULTI-BUTTON (TOP)		21	A-1380-627-A	K (VAR) MOUNTED PC BOARD	
7	1-529-638-11	SPEAKER (6X12CM)		22	1-766-374-11	PLUG, F-PIN	
8	2-163-920-01	PLATE, TLH CORRECTION		23	4-075-652-01	COVER, REAR	
9	1-452-896-11	COIL, NA ROTATION (RT200)		24	3-704-372-71	HOLDER, HV CABLE	
10	Δ 8-735-052-05	CRT 29RSN(FOR EQUATORIAL AREA) (KV-29FS12C ONLY)		25	4-062-047-01	PIECE A(110), CONV CORRECT	
10	Δ 8-735-041-05	CRT 29RSN (KV-29FS12 ONLY)		26	1-452-032-00	MAGNET, DISC	
11	4-053-005-01	SPACER, DY		27	Δ 1-453-310-11	FBT ASSY NX-4521/X4J4	28-30
12	Δ 8-451-494-31	DY Y29RSA-S		28	1-251-374-13	HV CAP ASSY	
13	A-1332-063-A	CA (VAR) MOUNTED PC BOARD		29	1-900-800-82	FOCUS LEAD	
14	A-1299-221-A	A COMPLETE PC BOARD	The high-voltage leads associated with the FBT on this board are not included and must be ordered separately. (See 28-30)	30	1-900-803-22	G2 LEAD	
15	4-036-329-01	SPRING (B), TENSION		31	A-1372-817-A	HX MOUNTED PC BOARD	
16	Δ 1-419-523-11	COIL, DEGAUSSING		32	Δ 8-453-011-11	NA299-M	
				33	4-062-970-01	CLIP (29RSN), DGC	
				34	Δ 8-598-431-30	TUNER, FSS BTF-WA411	

Note:

The components identified by shading and mark ▲ are critical for safety. Replace only with part number specified.

Note:

Les composants identifiés par un trame et une marque ▲ sont critiques pour la sécurité. Ne les remplacer que par une pièce portant le numéro spécifié.

7-2. CHASSIS (KV-27FS12/27FS16 ONLY)

- 7-685-648-79 SCREW +BVTP 3X12
- 7-685-663-79 SCREW +BVTP 4X16
- ▲ 4-046-765-12 SCREW (7) TAPPING

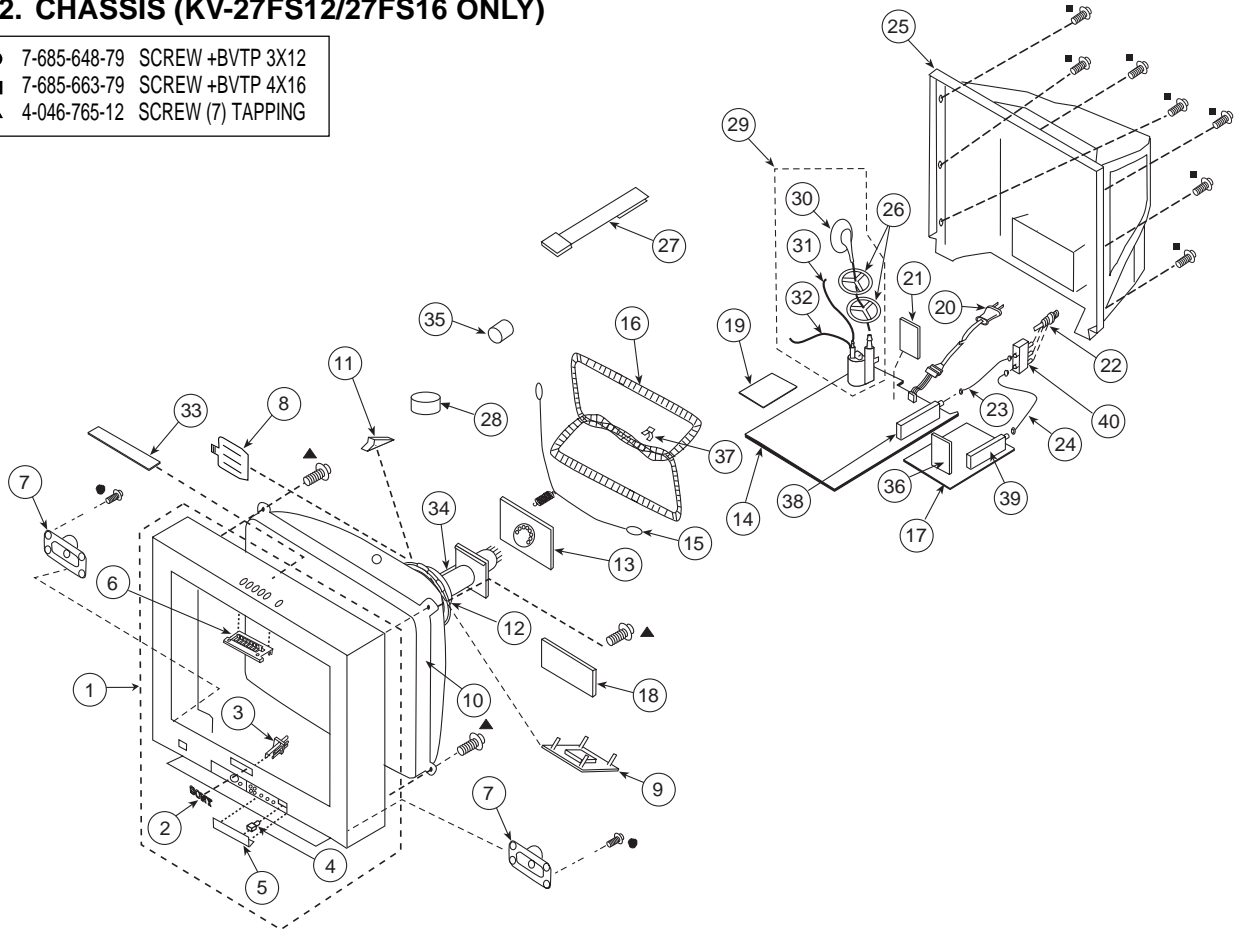

REF.NO.	PART.NO.	DESCRIPTION	REMARK
1	X-4037-663-1	BEZNET ASSY	2-5
2	3-704-179-31	EMBLEM (NO.9), SONY	
3	4-075-657-01	GUIDE, LED	
4	4-047-464-01	CATCHER, PUSH	
5	4-075-658-01	DOOR	
6	4-068-982-02	MULTI-BUTTON (TOP)	
7	1-529-498-11	SPEAKER (13.1X6.2CM)	
8	2-163-920-01	PLATE, TLH CORRECTION	
9	1-452-896-11	COIL, NA ROTATION (RT200)	
10	▲ 8-735-041-05	CRT 29RSN	
11	4-053-005-01	SPACER, DY	
12	▲ 8-451-494-31	DY Y29RSA-S	
13	* A-1332-063-A	CA (VAR) MOUNTED PC BOARD	
14	A-1299-222-A	A COMPLETE PC BOARD	
The high-voltage leads associated with the FBT on this board are not included and must be ordered separately. (See 30-32)			
15	4-036-329-01	SPRING (B), TENSION	
16	▲ 1-419-156-21	COIL, DEGAUSSING	
17	* A-1304-198-A	MA (VAR) MOUNTED PC BOARD (KV-27FS16 ONLY)	
17	* A-1304-200-A	MA (VAR) MOUNTED PC BOARD (KV-27FS12 ONLY)	
18	* A-1342-550-A	VA (VAR) MOUNTED PC BOARD	

REF.NO.	PART.NO.	DESCRIPTION	REMARK
19	* A-1343-875-A	D (VAR) MOUNTED PC BOARD	
20	▲ 1-792-874-11	CORD, POWER (WITH CONNECTOR)	
21	* A-1380-627-A	K (VAR) MOUNTED PC BOARD	
22	1-766-374-11	PLUG, F-PIN (KV-27FS16 ONLY)	
23	* 1-557-056-31	CABLE, P-P (KV-27FS16 ONLY)	
24	* 1-783-800-11	CABLE, PIN (KV-27FS16 ONLY)	
25	4-075-652-01	COVER, REAR	
26	3-704-372-71	HOLDER, HV CABLE	
27	4-062-047-01	PIECE A(110), CONV CORRECT	
28	1-452-032-00	MAGNET, DISC	
29	▲ 1-453-310-11	FBT ASSY NX-4521/X4J4	30-32
30	1-251-374-13	HV CAP ASSY	
31	1-900-800-82	FOCUS LEAD	
32	1-900-803-22	G2 LEAD	
33	* A-1372-817-A	HX MOUNTED PC BOARD	
34	▲ 8-453-011-11	NA299-M	
35	1-500-586-11	FILTER, CLAMP (FERRITE CORE)	
36	* A-1190-367-A	P MOUNTED PC BOARD (KV-27FS16 ONLY)	
37	* 4-062-970-01	CLIP (29RSN), DGC	
38	▲ 8-598-431-30	TUNER, FSS BTF-WA411	
39	▲ 8-598-501-00	TUNER, FSS BTF-FA402 (KV-27FS16 ONLY)	
40	8-598-414-20	CHANGER, ANTENNA AS-2F	

SECTION 8 ELECTRICAL PARTS LIST

A

Note:

The components identified by shading and mark \triangle are critical for safety. Replace only with part number specified.

The components identified by \boxtimes in this manual have been carefully factory-selected for each set in order to satisfy regulations regarding X-ray radiation. Should replacement be required, replace only with the value originally used.

Note:

Les composants identifiés par un trame et une marque \triangle sont critiques pour la sécurité. Ne les remplacer que par une pièce portant le numéro spécifié.

- Items marked * are not stocked since they are seldom required for routine service. Some delay should be anticipated when ordering these items.

- All variable and adjustable resistors have characteristic curve B, unless otherwise noted.

RESISTORS

- All resistors are in ohms
- F : nonflammable

When indicating parts by reference number, please include the board name.

REF. NO.	PART NO.	DESCRIPTION	REMARK	REF. NO.	PART NO.	DESCRIPTION	REMARK		
<div style="border: 1px solid black; padding: 5px; display: inline-block; font-size: 2em; font-weight: bold; margin-bottom: 10px;">A</div> <p>* A-1299-222-A A COMPLETE PC BOARD (KV-27FS12/27FS16 ONLY)</p> <p>* A-1299-221-A A COMPLETE PC BOARD (KV-29FS12/29FS12C ONLY)</p> <p>The high voltage leads associated with the FBT on this board are not included and must be ordered separately. Order the following leads when requesting this A Board:</p> <p>1-251-374-13 HV CAP ASSY 1-900-803-22 G2 LEAD 1-900-800-82 FOCUS LEAD</p> <p>1-533-223-11 HOLDER, FUSE</p> <p>* 4-374-846-11 COVER, CAPACITOR, CAP TYPE 4-382-854-11 SCREW (M3X10), P, SW (+) 4-382-854-11 SCREW (M3X10), P, SW (+)</p> <p>CAPACITOR</p> <p>C100 1-216-295-91 SHORT</p> <p>C101 1-216-295-91 SHORT</p> <p>C102 1-126-933-11 ELECT 100μF 20% 16V</p> <p>C104 1-126-941-11 ELECT 470μF 20% 25V</p> <p>C105 1-104-664-11 ELECT 47μF 20% 25V</p> <p>C204 1-163-017-00 CERAMIC CHIP 0.0047μF 10% 50V</p> <p>C205 1-126-963-11 ELECT 4.7μF 20% 50V</p> <p>C210 1-126-963-11 ELECT 4.7μF 20% 50V</p> <p>C214 1-164-346-11 CERAMIC CHIP 1μF 16V</p> <p>C215 1-164-346-11 CERAMIC CHIP 1μF 16V</p> <p>C216 1-126-963-11 ELECT 4.7μF 20% 50V</p> <p>C219 1-126-964-11 ELECT 10μF 20% 50V</p> <p>C402 1-126-943-11 ELECT 2200μF 20% 25V</p> <p>C403 1-126-957-11 ELECT 0.22μF 20% 50V</p> <p>C420 1-164-222-11 CERAMIC CHIP 0.22μF 25V</p> <p>C421 1-164-222-11 CERAMIC CHIP 0.22μF 25V</p> <p>C435 1-164-222-11 CERAMIC CHIP 0.22μF 25V (KV-29FS12/29FS12C ONLY)</p>				C441	1-164-346-11	CERAMIC CHIP	1 μ F	16V	
				C442	1-126-963-11	ELECT	4.7 μ F	20%	50V
				C501	1-102-114-00	CERAMIC	470PF	10%	50V
				C502	1-106-383-00	MYLAR	0.047 μ F	10%	200V
				C503	1-102-228-00	CERAMIC	470PF	10%	500V
				C504	1-102-228-00	CERAMIC	470PF	10%	500V
				C505	\triangle 1-162-116-00	CERAMIC	680PF	10%	2KV
				C506	1-162-318-11	CERAMIC	0.001 μ F	10%	500V
				C507	\triangle 1-117-717-11	FILM	17000PF	3%	1.2KV
				C508	\triangle 1-137-150-11	MYLAR	0.01 μ F	10%	100V
C509	\triangle 1-162-116-00	CERAMIC	680PF	10%	2KV				
C510	1-107-649-11	ELECT	2.2 μ F	20%	250V				
C511	1-115-522-11	FILM	1 μ F	5%	250V				
C512	\triangle 1-106-387-00	MYLAR	0.068 μ F	10%	200V				
C513	1-106-343-00	MYLAR	0.001 μ F	10%	100V				
C514	1-109-844-11	FILM	0.68 μ F	5%	250V				
C515	\triangle 1-162-116-00	CERAMIC	680PF	10%	2KV				
C520	\triangle 1-129-722-00	FILM	0.047 μ F	5%	630V				
C521	1-164-646-11	CERAMIC	2200PF	10%	500V				
C523	1-126-941-11	ELECT	470 μ F	20%	25V				
C524	1-102-244-00	CERAMIC	220PF	10%	500V				
C525	1-107-612-11	CERAMIC	100PF	5%	500V				
C526	1-126-960-11	ELECT	1 μ F	20%	50V				
C527	1-126-965-11	ELECT	22 μ F	20%	50V				
C528	1-164-161-11	CERAMIC CHIP	0.0022 μ F	10%	50V				
C529	1-164-161-11	CERAMIC CHIP	0.0022 μ F	10%	50V				
C530	1-164-161-11	CERAMIC CHIP	0.0022UF	10%	50V				
C531	1-106-387-00	MYLAR	0.068 μ F	10%	200V				
C533	1-126-941-11	ELECT	470 μ F	20%	25V				
C534	\triangle 1-126-964-11	ELECT	10 μ F	20%	50V				
C535	1-126-959-11	ELECT	0.47 μ F	20%	50V				
C536	1-102-228-00	CERAMIC	470PF	10%	500V				
C537	\triangle 1-126-965-11	ELECT	22 μ F	20%	50V				
C539	1-107-662-11	ELECT	22 μ F	20%	250V				
C540	1-107-645-11	ELECT	22UF	20%	160V				
C541	1-126-969-11	ELECT	220 μ F	20%	50V				
C542	1-126-967-11	ELECT	47 μ F	20%	50V				
C543	1-136-169-00	MYLAR	0.22 μ F	5%	50V				
C546	\triangle 1-126-965-11	ELECT	22 μ F	20%	50V				

A

Note:

The components identified by shading and mark \triangle are critical for safety. Replace only with part number specified.

Note:

Les composants identifiés par un trame et une marque \triangle sont critiques pour la sécurité. Ne les remplacer que par une pièce portant le numéro spécifié.

REF.NO.	PART NO.	DESCRIPTION	REMARK	REF.NO.	PART NO.	DESCRIPTION	REMARK
DIODE							
D204	8-719-982-22	DIODE MTZJ-T-77-30D		D612	8-719-110-17	DIODE MTZJ-T-77-10B	
D208	8-719-110-17	DIODE MTZJ-T-77-10B		D613	8-719-063-70	DIODE D1NL20U-TA	
D209	8-719-977-22	DIODE UDZ-TE-17-9.1B		D614	8-719-063-70	DIODE D1NL20U-TA	
D210	8-719-110-17	DIODE MTZJ-T-77-10B		D615	8-719-312-10	DIODE RU4AM-T3	
D211	8-719-108-12	DIODE RD9.1EW-T1		D616	8-719-510-37	DIODE D5LC20U	
D212	8-719-110-17	DIODE MTZJ-T-77-10B		D617	8-719-110-31	DIODE MTZJ-T-77-12C	
D213	8-719-110-17	DIODE MTZJ-T-77-10B		D618	8-719-991-33	DIODE 1SS133T-77	
D214	8-719-108-12	DIODE RD9.1EW-T1		D619	8-719-110-17	DIODE MTZJ-T-77-10B	
D215	8-719-108-12	DIODE RD9.1EW-T1		D620	8-719-510-37	DIODE D5LC20U	
D230	8-719-108-12	DIODE RD9.1EW-T1		D622	8-719-077-76	DIODE D2SB60A-F04	
D231	8-719-108-12	DIODE RD9.1EW-T1		D623	8-719-948-45	DIODE ERA22-08TP3	
D232	8-719-108-12	DIODE RD9.1EW-T1		D624	8-719-991-33	DIODE 1SS133T-77	
D233	8-719-108-12	DIODE RD9.1EW-T1		D625	8-719-991-33	DIODE 1SS133T-77	
D401	8-719-110-17	DIODE MTZJ-T-77-10B		D626	8-719-063-70	DIODE D1NL20U-TA	
D501	8-719-945-80	DIODE ERC06-15S		D627	8-719-110-03	DIODE MTZJ-T-77-7100A	
D502	8-719-908-03	DIODE GP08DPKG23		D628	8-719-510-48	DIODE D1N20R-TA	
D503	8-719-908-03	DIODE GP08DPKG23		D2001	8-719-070-80	DIODE LNK0120022G	
D504	8-719-945-80	DIODE ERC06-15S		D2002	8-719-110-17	DIODE MTZJ-T-77-10B	
D505	8-719-312-10	DIODE RU4AM-T3		D2003	8-719-108-12	DIODE RD9.1EW-T1	
D506	8-719-302-43	DIODE RGP10GPKG3		D2004	8-719-921-44	DIODE MTZJ-T-77-5.1C	
D507	8-719-991-33	DIODE 1SS133T-77		D2005	8-719-921-44	DIODE MTZJ-T-77-5.1C	
D508	8-719-991-33	DIODE 1SS133T-77		FUSE			
D509	8-719-109-89	DIODE MTZJ-T-77-5.6C		F601	\triangle 1-576-193-11	FUSE 6.3A/125V (KV-27FS12/27FS16 ONLY)	
D510	8-719-908-03	DIODE GP08DPKG23		F601	\triangle 1-532-506-51	FUSE 6.3A/250V (KV-29FS12/29FS12C ONLY)	
D511	8-719-302-43	DIODE RGP10GPKG23		FERRITE BEAD			
D512	8-719-073-01	DIODE MA111-TX		FB501	1-410-397-21	FERRITE	1.1 μ H
D513	8-719-979-85	DIODE RGP15GPKG23		FB502	1-410-397-21	FERRITE	1.1 μ H
D514	8-719-979-85	DIODE RGP15GPKG23		FB503	1-410-397-21	FERRITE	1.1 μ H
D515	8-719-073-01	DIODE MA111-TX		FB600	1-412-911-11	FERRITE	0 μ H
D516	\triangle 8-719-991-33	DIODE 1SS133T-77		FB601	1-412-911-11	FERRITE	0 μ H
D517	\triangle 8-719-991-33	DIODE 1SS133T-77		FB602	1-412-911-11	FERRITE	0 μ H
D518	\triangle 8-719-921-63	DIODE MTZJ-T-77-7100X		FB603	1-412-911-11	FERRITE	0 μ H
D519	\triangle 8-719-302-43	DIODE EL12-V1		FB604	1-412-911-11	FERRITE	0 μ H
D520	\triangle 8-719-073-01	DIODE MA111-TX		FB605	1-412-911-11	FERRITE	0 μ H
D521	8-719-991-33	DIODE 1SS133T-77		FB606	1-412-911-11	FERRITE	0 μ H
D522	8-719-991-33	DIODE 1SS133T-77		FB609	1-412-911-11	FERRITE	0 μ H
D601	8-719-991-33	DIODE 1SS133T-77		FB610	1-412-911-11	FERRITE	0 μ H
D602	8-719-991-33	DIODE 1SS133T-77		IC			
D603	8-719-982-26	DIODE MTZJ-T-77-33B		IC401	8-759-490-17	IC TDA7057AQ/N2 (KV-27FS12/27FS16 ONLY)	
D604	8-719-028-72	DIODE RGP02-17PKG23		IC402	8-759-573-40	IC TDA8580Q/N1 (KV-29FS12/29FS12C ONLY)	
D605	\triangle 8-719-510-53	DIODE D4SB60L-F		IC501	\triangle 8-759-700-07	IC NJM2903M-TE2	
D606	\triangle 8-719-108-18	DIODE TF541M		IC502	8-759-980-58	IC TDA8172	
D607	8-719-991-33	DIODE 1SS133T-77					
D608	8-719-110-53	DIODE MTZJ-T-77-20B					
D609	8-719-311-31	DIODE RU-1P (KV-29FS12/29FS12C ONLY)					
D610	8-719-510-02	DIODE D1NS4-TA					
D611	8-719-063-70	DIODE D1NL20U-TA					

Note:

The components identified by shading and mark \triangle are critical for safety. Replace only with part number specified.

Note:

Les composants identifiés par un trame et une marque \triangle sont critiques pour la sécurité. Ne les remplacer que par une pièce portant le numéro spécifié.

A

REF.NO.	PART NO.	DESCRIPTION	REMARK	REF.NO.	PART NO.	DESCRIPTION	REMARK
IC601	\triangle 8-749-015-61	IC STR-F6626 (KV-27FS12/27FS16 ONLY)		L604	1-412-525-31	INDUCTOR	10 μ H
IC601	\triangle 8-749-014-48	IC STR-F6656 (KV-29FS12/29FS12C ONLY)		L605	1-412-529-11	INDUCTOR	22 μ H
IC602	\triangle 8-749-016-47	IC EA135-F12		PHOTO COUPLER			
IC603	8-759-198-03	IC PQ09RF21		PH601	\triangle 8-749-010-64	PHOTO COUPLER PC123FY2	
IC604	8-759-701-75	IC NJM7805FA		IC LINK			
IC2001	8-742-212-20	HYB IC SBX3081-71		PS401	\triangle 1-576-336-21	LINK, IC (KV-27FS12/27FS16 ONLY)	
JACK				PS401	\triangle 1-532-686-21	LINK, IC 2.7A/150V (KV-29FS12/29FS12C ONLY)	
J201	1-794-119-11	TERMINAL BLOCK, S 4P		TRANSISTOR			
J202	1-794-267-11	JACK, PIN 3P		Q101	8-729-422-27	TRANSISTOR 2SD601A-QRS-TX	
J203	1-794-118-11	JACK BLOCK, PIN 3P		Q410	8-729-422-27	TRANSISTOR 2SD601A-QRS-TX	
J205	1-794-116-11	JACK BLOCK, PIN 2P		Q411	8-729-216-22	TRANSISTOR 2SB709A-QRS-TX	
J206	1-794-117-11	JACK BLOCK, PIN 2P		Q501	8-729-140-50	TRANSISTOR 2SC3209LK-TP	
J402	1-794-116-11	JACK BLOCK, PIN 2P		Q502	\triangle 8-729-046-07	TRANSISTOR 2SD2578-YB	
CHIP CONDUCTOR				Q503	8-729-422-27	TRANSISTOR 2SD601A-QRS-TX	
JR001	1-216-295-91	SHORT		Q504	8-729-809-29	TRANSISTOR 2SC4159-E	
JR002	1-216-295-91	SHORT		Q505	\triangle 8-729-200-17	TRANSISTOR 2SA1091O-TPE2	
JR403	1-216-295-91	SHORT		Q506	\triangle 8-729-422-27	TRANSISTOR 2SD601A-QRS-TX	
JR405	1-216-295-91	SHORT (KV-29FS12/29FS12C ONLY)		Q507	\triangle 8-729-216-22	TRANSISTOR 2SB709A-QRS-TX	
JR411	1-216-295-91	SHORT		Q601	8-729-922-37	TRANSISTOR 2SD2144S-TP-UVW	
JR471	1-216-295-91	SHORT (KV-29FS12/29FS12C ONLY)		Q602	8-729-423-33	TRANSISTOR 2SC3311A-QRSTA	
JR472	1-216-295-91	SHORT		Q603	8-729-119-76	TRANSISTOR 2SA1309A-QRSTA	
JR502	1-216-295-91	SHORT		Q604	8-729-422-27	TRANSISTOR 2SD601A-QRS-TX	
JR503	1-216-295-91	SHORT		Q605	\triangle 8-729-046-40	TRANSISTOR 2SK2663	
JR505	1-216-295-91	SHORT (KV-27FS12/27FS16 ONLY)		Q606	8-729-422-27	TRANSISTOR 2SD601A-QRS-TX	
JR522	1-216-295-91	SHORT		Q607	8-729-922-37	TRANSISTOR 2SD2144S-TP-UVW	
JR523	1-216-295-91	SHORT		Q608	8-729-422-27	TRANSISTOR 2SD601A-QRS-TX	
JR526	1-216-295-91	SHORT		Q609	8-729-423-33	TRANSISTOR 2SC3311A-QRSTA	
JR527	1-216-295-91	SHORT		RESISTOR			
COIL				R105	1-216-065-91	RES-CHIP	4.7K 5% 1/10W
L101	1-412-029-11	INDUCTOR CHIP	10 μ H	R107	1-216-025-91	RES-CHIP	100 5% 1/10W
L102	1-412-032-11	INDUCTOR CHIP	100 μ H	R108	1-216-025-91	RES-CHIP	100 5% 1/10W
L103	1-412-029-11	INDUCTOR CHIP	10 μ H	R115	1-216-295-91	SHORT	
L501	1-409-955-11	INDUCTOR	8mH	R201	1-216-113-00	RES-CHIP	470K 5% 1/10W
L502	1-412-552-11	INDUCTOR	2.2mH	R202	1-216-113-00	RES-CHIP	470K 5% 1/10W
L503	1-406-677-11	INDUCTOR	10mH	R204	1-216-081-00	RES-CHIP	22K 5% 1/10W
L504	1-412-533-21	INDUCTOR	47 μ H	R205	1-216-085-00	RES-CHIP	33K 5% 1/10W
L505	1-406-978-11	INDUCTOR	150 μ H	R208	1-215-924-00	METAL OXIDE	15K 5% 3W
L506	1-406-677-11	INDUCTOR	10mH	R214	1-216-113-00	RES-CHIP	470K 5% 1/10W
L507	1-412-552-11	INDUCTOR	2.2mH	R215	1-216-113-00	RES-CHIP	470K 5% 1/10W
L510	\triangle 1-412-528-11	INDUCTOR	18 μ H	R235	1-216-113-00	RES-CHIP	470K 5% 1/10W
L603	1-412-529-11	INDUCTOR	22 μ H	R237	1-216-033-00	RES-CHIP	220 5% 1/10W

KV-27FS12/27FS16/29FS12/29FS12C



Note:

The components identified by shading and mark \triangle are critical for safety. Replace only with part number specified.

Note:

Les composants identifiés par un trame et une marque \triangle sont critiques pour la sécurité. Ne les remplacer que par une pièce portant le numéro spécifié.

REF.NO.	PART NO.	DESCRIPTION	REMARK	REF.NO.	PART NO.	DESCRIPTION	REMARK
R238	1-216-033-00	RES-CHIP	220 5% 1/10W	R510	1-249-411-11	CARBON	330 5% 1/4W
R239	1-216-113-00	RES-CHIP	470K 5% 1/10W	R511	1-249-377-11	CARBON	0.47 5% 1/4W
R401	1-216-080-00	RES-CHIP (KV-29FS12/29FS12C ONLY)	20K 5% 1/10W	R512	1-215-910-00	METAL OXIDE	68 5% 3W
R402	1-216-073-00	RES-CHIP (KV-29FS12/29FS12C ONLY)	10K 5% 1/10W	R513 \triangle	1-215-907-11	METAL OXIDE	22 5% 3W
R411	1-249-417-11	CARBON	1K 5% 1/4W	R514	1-216-683-11	METAL CHIP	22K 0.50% 1/10W
R412	1-216-113-00	RES-CHIP	470K 5% 1/10W	R516	1-249-425-11	CARBON	4.7K 5% 1/4W
R413	1-216-113-00	RES-CHIP	470K 5% 1/10W	R517	1-215-445-00	METAL	10K 1% 1/4W
R414	1-249-417-11	CARBON	1K 5% 1/4W	R518	1-249-427-11	CARBON	6.8K 5% 1/4W
R420	1-216-073-00	RES-CHIP (KV-27FS12/27FS16 ONLY)	10K 5% 1/10W	R519	1-249-427-11	CARBON	6.8K 5% 1/4W
R421	1-249-425-11	CARBON	4.7K 5% 1/4W	R520 \triangle	1-215-884-11	METAL OXIDE	47 5% 2W
R422	1-249-389-11	CARBON	4.7 5% 1/4W	R521	1-249-413-11	CARBON	470 5% 1/4W
R426	1-216-009-91	RES-CHIP (KV-29FS12/29FS12C ONLY)	22 5% 1/10W	R522	1-249-417-11	CARBON	1K 5% 1/4W
R429	1-216-113-00	RES-CHIP	470K 5% 1/10W	R523	1-216-073-00	RES-CHIP	10K 5% 1/10W
R430	1-216-049-91	RES-CHIP	1K 5% 1/10W	R524	1-249-429-11	CARBON	10K 5% 1/4W
R431	1-216-049-91	RES-CHIP	1K 5% 1/10W	R525 \triangle	1-208-804-11	METAL CHIP	8.2K 0.50% 1/10W
R433	1-216-113-00	RES-CHIP	470K 5% 1/10W	R526	1-208-814-91	METAL CHIP	22K 0.50% 1/10W
R436	1-216-073-00	RES-CHIP (KV-27FS12/27FS16 ONLY)	10K 5% 1/10W	R528	1-215-429-00	METAL	2.2K 1% 1/4W
R436	1-216-081-00	RES-CHIP (KV-29FS12/29FS12C ONLY)	22K 5% 1/10W	R529	1-216-109-00	RES-CHIP	330K 5% 1/10W
R437	1-216-073-00	RES-CHIP (KV-27FS12/27FS16 ONLY)	10K 5% 1/10W	R530	1-216-077-91	RES-CHIP	15K 5% 1/10W
R437	1-216-065-91	RES-CHIP (KV-29FS12/29FS12C ONLY)	4.7K 5% 1/10W	R532	1-215-437-00	METAL	4.7K 1% 1/4W
R438	1-216-073-00	RES-CHIP (KV-27FS12/27FS16 ONLY)	10K 5% 1/10W	R533	1-215-457-00	METAL	33K 1% 1/4W
R438	1-216-081-00	RES-CHIP (KV-29FS12/29FS12C ONLY)	22K 5% 1/10W	R534	1-215-458-00	METAL	36K 1% 1/4W
R439	1-216-073-00	RES-CHIP (KV-27FS12/27FS16 ONLY)	10K 5% 1/10W	R535	1-249-441-11	CARBON	100K 5% 1/4W
R439	1-216-065-91	RES-CHIP (KV-29FS12/29FS12C ONLY)	4.7K 5% 1/10W	R536 \triangle	1-214-798-21	METAL	1.8 1% 1/2W
R440	1-216-097-91	RES-CHIP	100K 5% 1/10W	R537	1-249-401-11	CARBON	47 5% 1/4W
R441	1-216-081-00	RES-CHIP	22K 5% 1/10W	R538 \triangle	1-215-889-00	METAL OXIDE	330 5% 2W
R442	1-216-025-91	RES-CHIP	100 5% 1/10W	R539	1-249-385-11	CARBON	2.2 5% 1/4W
R445	1-216-073-00	RES-CHIP	10K 5% 1/10W	R540	1-215-445-00	METAL	10K 1% 1/4W
R446	1-249-435-11	CARBON	33K 5% 1/4W	R541	1-249-429-11	CARBON	10K 5% 1/4W
R447	1-216-065-91	RES-CHIP	4.7K 5% 1/10W	R543	1-247-887-00	CARBON	220K 5% 1/4W
R454	1-216-025-91	RES-CHIP	100 5% 1/10W	R544	1-249-377-11	CARBON	0.47 5% 1/4W
R501	1-249-425-11	CARBON	4.7K 5% 1/4W	R545	1-215-873-00	METAL OXIDE	4.7K 5% 1W
R502 \triangle	1-216-455-21	METAL OXIDE	560 5% 2W	R546 \triangle	1-249-377-11	CARBON	0.47 5% 1/4W
R503 \triangle	1-249-425-11	CARBON	4.7K 5% 1/4W	R547	1-216-455-21	METAL OXIDE	560 5% 2W
R505	1-249-401-11	CARBON	47 5% 1/4W	R548	1-216-377-11	METAL OXIDE	4.7 5% 2W
R506 \triangle	1-215-883-11	METAL OXIDE	33 5% 2W	R549 \triangle	1-260-288-11	CARBON	0.47 5% 1/2W
R507 \triangle	1-260-328-11	CARBON	1K 5% 1/2W	R550 \triangle	1-260-288-11	CARBON	0.47 5% 1/2W
R508	1-247-863-91	CARBON	22K 5% 1/4W	R551	1-215-907-11	METAL OXIDE	22 5% 3W
R509 \triangle	1-215-891-11	METAL OXIDE	680 5% 2W	R553 \triangle	1-216-363-00	METAL OXIDE	0.33 5% 2W
				R554 \triangle	1-249-429-11	CARBON	10K 5% 1/4W
				R555 \triangle	1-247-895-91	CARBON	470K 5% 1/4W
				R556 \triangle	1-249-417-11	CARBON	1K 5% 1/4W
				R557 \triangle	1-247-895-91	CARBON	470K 5% 1/4W
				R558 \triangle	1-216-097-91	RES-CHIP	100K 5% 1/10W
				R559 \triangle	1-216-073-00	RES-CHIP	10K 5% 1/10W
				R560 \triangle	1-215-902-11	METAL OXIDE	47K 5% 1W
				R561 \triangle	1-249-406-11	CARBON	120 5% 1/4W
				R562 \triangle	1-208-808-11	METAL CHIP	12K 0.50% 1/10W
				R563 \triangle	1-247-863-91	CARBON	22K 5% 1/4W

Note:

The components identified by shading and mark Δ are critical for safety. Replace only with part number specified.

Note:

The components identified by \square in this manual have been carefully factory-selected for each set in order to satisfy regulations regarding x-ray radiation. Should replacement be required, replace only with the value originally used.



REF.NO.	PART NO.	DESCRIPTION	REMARK	REF.NO.	PART NO.	DESCRIPTION	REMARK
\square R564 Δ	1-208-836-11	METAL CHIP	180K 0.50% 1/10W	R638	1-249-402-11	CARBON 56 5% 1/4W (KV-29FS12/29FS12C ONLY)	
R565 Δ	1-249-429-11	CARBON	10K 5% 1/4W	R639	1-249-421-11	CARBON 2.2K 5% 1/4W	
R566 Δ	1-216-073-00	RES-CHIP	10K 5% 1/10W	R640	1-249-417-11	CARBON 1K 5% 1/4W	
R567 Δ	1-216-073-00	RES-CHIP	10K 5% 1/10W	R641 Δ	1-216-362-11	METAL OXIDE 0.27 5% 2W	
R568 Δ	1-215-882-00	METAL OXIDE	22 5% 2W	R642	1-216-089-91	RES-CHIP 47K 5% 1/10W	
R569	1-214-798-21	METAL	1.8 1% 1/2W	R643	1-249-419-11	CARBON 1.5K 5% 1/4W	
R570	1-247-863-91	CARBON	22K 5% 1/4W	R644	1-247-843-11	CARBON 3.3K 5% 1/4W	
R571	1-216-065-91	RES-CHIP	4.7K 5% 1/10W	R645	1-215-898-11	METAL OXIDE 10K 5% 2W	
R572	1-216-065-91	RES-CHIP	4.7K 5% 1/10W	R646	1-249-419-11	CARBON 1.5K 5% 1/4W	
R601 Δ	1-219-513-11	CARBON (KV-27FS12/27FS16 ONLY)	4.7M 5% 1/2W	R648	1-215-908-00	METAL OXIDE 33 5% 3W	
R602 Δ	1-249-389-11	CARBON	4.7 5% 1/4W	R649	1-249-417-11	CARBON 1K 5% 1/4W	
R603	1-215-485-00	METAL	470K 1% 1/4W	R650	1-216-387-11	METAL OXIDE 0.68 5% 3W	
R607	1-215-859-00	METAL OXIDE	22 5% 1W	R651	1-249-429-11	CARBON 10K 5% 1/4W	
R608	1-240-205-11	CARBON	22M 5% 1/2W	R653	1-216-049-91	RES-CHIP 1K 5% 1/10W	
R609	1-216-049-91	RES-CHIP	1K 5% 1/10W	R655	1-216-049-91	RES-CHIP 1K 5% 1/10W	
R610	1-216-073-00	RES-CHIP	10K 5% 1/10W	R656	1-249-429-11	CARBON 10K 5% 1/4W	
R611	1-216-089-91	RES-CHIP	47K 5% 1/10W	R658	1-216-387-11	METAL OXIDE 0.68 5% 3W	
R612	1-216-045-00	RES-CHIP	680 5% 1/10W	R659	1-215-857-11	METAL OXIDE 10 5% 1W	
R613 Δ	1-219-512-11	CARBON	2.2M 5% 1/2W	R660 Δ	1-215-924-00	METAL OXIDE 15K 5% 3W (KV-27FS12/27FS16 ONLY)	
R614	1-249-413-11	CARBON	470 5% 1/4W	R660 Δ	1-216-485-11	METAL OXIDE 5.6K 5% 3W (KV-29FS12/29FS12C ONLY)	
R615 Δ	1-218-265-11	METAL (KV-29FS12/29FS12C ONLY)	8.2M 5% 1W	R661	1-216-057-00	RES-CHIP 2.2K 5% 1/10W	
R616 Δ	1-260-302-51	CARBON	6.8 5% 1/2W	R662 Δ	1-216-485-11	METAL OXIDE 5.6K 5% 3W (KV-29FS12/29FS12C ONLY)	
R617	1-216-009-91	RES-CHIP	22 5% 1/10W	R663	1-216-081-00	RES-CHIP 22K 5% 1/10W	
R618	1-249-440-11	CARBON	82K 5% 1/4W	R2001	1-216-057-00	RES-CHIP 2.2K 5% 1/10W	
R619	1-249-437-11	CARBON	47K 5% 1/4W	R2002	1-216-053-00	RES-CHIP 1.5K 5% 1/10W	
R620	1-249-417-11	CARBON	1K 5% 1/4W	R2003	1-249-425-11	CARBON 4.7K 5% 1/4W	
R621 Δ	1-240-251-11	CEMENTED	6.8 5% 10W	R2004	1-216-069-00	RES-CHIP 6.8K 5% 1/10W	
R622	1-249-441-11	CARBON	100K 5% 1/4W	R2005	1-216-295-91	SHORT	
R623 Δ	1-260-324-11	CARBON	470 5% 1/2W				
R624 Δ	1-249-429-11	CARBON	10K 5% 1/4W				
R625	1-249-437-11	CARBON	47K 5% 1/4W				
R626 Δ	1-220-926-11	FUSIBLE	0.47 10% 1/2W				
R627	1-215-483-00	METAL (KV-27FS12/27FS16 ONLY)	390K 1% 1/4W				
R627	1-215-479-00	METAL (KV-29FS12/29FS12C ONLY)	270K 1% 1/4W				
R630	1-249-421-11	CARBON	2.2K 5% 1/4W				
R631	1-215-929-11	METAL OXIDE (KV-29FS12/29FS12C ONLY)	100K 5% 3W				
R632 Δ	1-216-361-21	METAL OXIDE	0.22 5% 2W				
R633	1-249-415-11	CARBON	680 5% 1/4W				
R634	1-216-073-00	RES-CHIP	10K 5% 1/10W				
R635	1-216-057-00	RES-CHIP	2.2K 5% 1/10W				
R637 Δ	1-216-485-11	METAL OXIDE (KV-29FS12/29FS12C ONLY)	5.6K 5% 3W				
R638	1-249-399-11	CARBON (KV-27FS12/27FS16 ONLY)	33 5% 1/4W				
				RELAY			
				RY601 Δ	1-755-198-11	RELAY	
				RY602 Δ	1-755-266-11	RELAY, AC POWER	
				SWITCH			
				S2007	1-762-816-11	SWITCH, TACTILE	
				S2008	1-762-816-11	SWITCH, TACTILE	
				SWITCH			
				SW501	1-572-707-11	SWITCH, LEVER	
				SW502	1-572-707-11	SWITCH, LEVER	

**Note:**

The components identified by shading and mark \triangle are critical for safety. Replace only with part number specified.

Note:

Les composants identifiés par un trame et une marque \triangle sont critiques pour la sécurité. Ne les remplacer que par une pièce portant le numéro spécifié.

REF.NO.	PART NO.	DESCRIPTION	REMARK	REF.NO.	PART NO.	DESCRIPTION	REMARK
TRANSFORMER							
T501	\triangle 1-437-195-11	TRANSFORMER, HORIZONTAL DRIVE		C708	1-136-165-00	MYLAR	0.1 μ F 5% 50V
T503	\triangle 1-426-981-11	TRANSFORMER, FERRITE (PMT)		C709	1-126-934-11	ELECT	220 μ F 20% 16V
T504	\triangle 1-431-693-11	TRANSFORMER, HORIZONTAL LINEAR		C710	1-126-964-11	ELECT	10 μ F 20% 50V
T505	\triangle 1-453-310-11	FBT ASSY NX-4521//X4J4		CONNECTOR			
T602	\triangle 1-435-617-11	TRANSFORMER, LINE FILTER (KV-27FS12/27FS16 ONLY)		CN701 *	1-564-506-11	PLUG, CONNECTOR 3P	
T602	\triangle 1-426-717-11	TRANSFORMER, LINE FILTER (LFT) (KV-29FS12/29FS12C ONLY)		CN702	1-695-915-11	TAB (CONTACT)	
T603	\triangle 1-433-806-11	TRANSFORMER, REGULAT (KV-27FS12/27FS16 ONLY)		CN704	1-695-915-11	TAB (CONTACT)	
T603	\triangle 1-433-807-11	TRANSFORMER, REGULAT (KV-29FS12/29FS12C ONLY)		CN705 *	1-564-512-11	PLUG, CONNECTOR 9P	
T604	\triangle 1-431-852-11	TRANSFORMER, CONVERTER (SRT)		CN706 *	1-564-509-11	PLUG, CONNECTOR 6P	
THERMISTOR				DIODE			
TH501	1-800-193-00	THERMISTOR		D701	8-719-901-83	DIODE 1SS83TD	
TH601	\triangle 1-803-586-11	THERMISTOR, NTC		D702	8-719-901-83	DIODE 1SS83TD	
THERMISTOR				D703	8-719-901-83	DIODE 1SS83TD	
THP601	\triangle 1-803-540-11	THERMISTOR		D704	8-719-302-43	DIODE RGP10GPKG23	
TUNER				IC			
TU101	\triangle 8-598-431-30	TUNER, FSS BTF-WA411		IC701	8-759-803-42	IC LA6500-FA	
VARISTOR				IC702	8-759-562-43	IC TDA6108JF/N1B	
VDR601	\triangle 1-803-585-11	VARISTOR ENE271D-10A (KV-27FS12/27FS16 ONLY)		JACK			
VDR601	\triangle 1-803-967-11	VARISTOR (ENE621D-14A) (KV-29FS12/29FS12C ONLY)		J701	\triangle 1-451-470-21	SOCKET, CRT	
CAPACITOR				COIL			
C701	1-104-664-11	ELECT	47 μ F 20% 25V	L701	1-408-613-31	INDUCTOR	68 μ H
C702	1-136-165-00	MYLAR	0.1 μ F 5% 50V	TRANSISTOR			
C703	1-104-664-11	ELECT	47 μ F 20% 25V	Q700	8-729-423-33	TRANSISTOR 2SC3311A-QRSTA	
C704	1-107-651-11	ELECT	4.7 μ F 20% 250V	Q701	8-729-423-33	TRANSISTOR 2SC3311A-QRSTA	
C705	1-107-652-11	ELECT	10 μ F 20% 250V	RESISTOR			
C707	1-162-114-00	CERAMIC	0.0047 μ F 2KV	R700	1-247-863-91	CARBON	22K 5% 1/4W
				R701	1-249-429-11	CARBON	10K 5% 1/4W
				R702	1-247-815-91	CARBON	220 5% 1/4W
				R703	1-247-807-31	CARBON	100 5% 1/4W
				R704	1-249-421-11	CARBON	2.2K 5% 1/4W
				R705	1-249-429-11	CARBON	10K 5% 1/4W
				R706	1-249-381-11	CARBON	1 5% 1/4W
				R707	1-249-383-11	CARBON	1.5 5% 1/4W
				R708	1-247-807-31	CARBON	100 5% 1/4W
				R709	1-247-807-31	CARBON	100 5% 1/4W

* A-1332-063-A CA (VAR) MOUNTED PC BOARD

4-382-854-11 SCREW (M3X10),P, SW (+)

Note:

The components identified by shading and mark \triangle are critical for safety. Replace only with part number specified.

Note:

Les composants identifiés par un trame et une marque \triangle sont critiques pour la sécurité. Ne les remplacer que par une pièce portant le numéro spécifié.



REF.NO.	PART NO.	DESCRIPTION	REMARK	REF.NO.	PART NO.	DESCRIPTION	REMARK
R710	1-247-807-31	CARBON	100 5% 1/4W				
R711	1-260-099-11	CARBON	1K 5% 1/2W				
R712	1-260-099-11	CARBON	1K 5% 1/2W				
R713	1-260-099-11	CARBON	1K 5% 1/2W				
R714	1-260-087-11	CARBON	100 5% 1/2W				
R715	1-260-132-11	CARBON	560K 5% 1/2W				
R716	1-260-123-11	CARBON	100K 5% 1/2W				
R717	1-216-373-11	METAL OXIDE	2.2 5% 2W				
R719	1-215-888-00	METAL OXIDE	220 5% 2W				
R720	1-249-421-11	CARBON	2.2K 5% 1/4W				
R721	1-249-421-11	CARBON	2.2K 5% 1/4W				
VARIABLE RESISTOR							
RV701	1-241-656-11	RES, ADJ, METAL FILM 110M					
D							
* A-1343-875-A D (VAR) MOUNTED PC BOARD							
CAPACITOR							
C801	1-117-534-91	ELECT	1 μ F 20% 100V				
C802	1-117-511-91	ELECT	10 μ F 20% 50V				
C803	1-136-191-11	MYLAR	0.22 μ F 5% 63V				
C804	1-136-191-11	MYLAR	0.22 μ F 5% 63V				
C807	1-163-021-91	CERAMIC CHIP	0.01 μ F 10% 50V				
C808	1-163-021-91	CERAMIC CHIP	0.01 μ F 10% 50V				
C809	1-110-501-11	CERAMIC CHIP	0.33 μ F 10% 16V				
C810	1-130-495-00	MYLAR	0.1 μ F 5% 50V				
C812	1-163-021-91	CERAMIC CHIP	0.01 μ F 10% 50V				
C814	1-163-021-91	CERAMIC CHIP	0.01 μ F 10% 50V				
C815	1-129-718-00	FILM	0.022 μ F 5% 630V				
C816	1-102-244-00	CERAMIC	220PF 10% 500V				
C817	1-136-558-11	FILM	0.0039 μ F 5% 630V				
C818	1-164-735-51	CERAMIC	0.0015 μ F 10% 500V				
C820	1-109-954-11	ELECT	0.47 μ F 20% 160V				
C821	1-163-021-91	CERAMIC CHIP	0.01 μ F 10% 50V				
C823	1-130-967-00	FILM	0.0027 μ F 5% 50V				
C824	1-104-760-11	CERAMIC CHIP	0.047 μ F 10% 50V				
C825	1-137-150-11	MYLAR	0.01 μ F 5% 50V				
C826	1-163-251-11	CERAMIC CHIP	100PF 5% 50V				
C862	1-117-511-91	ELECT	10 μ F 20% 50V				
CONNECTOR							
CN800 *	1-564-510-11	PLUG, CONNECTOR 7P					
CN801 *	1-564-507-11	PLUG, CONNECTOR 4P					
CN802 *	1-508-784-21	PIN, CONNECTOR (5MM PITCH) 1P					
DIODE							
D801	8-719-109-89	DIODE MTZJ-T-77-5.6C					
D802	8-719-991-33	DIODE 1SS133T-77					
D808	8-719-991-33	DIODE 1SS133T-77					
D809	8-719-110-41	DIODE MTZJ-T-77-15B					
D810	8-719-970-87	DIODE ERA38-06TP1					
D811	8-719-970-87	DIODE ERA38-06TP1					
D812	8-719-300-33	DIODE ERB44-06TP1					
D813	8-719-991-33	DIODE 1SS133T-77					
D814	8-719-991-33	DIODE 1SS133T-77					
IC							
IC801	8-759-700-42	IC NJM2904D					
IC802	8-759-659-67	IC NJM2903D					
IC803	8-759-659-67	IC NJM2903D					
CHIP CONDUCTOR							
JR801	1-216-295-91	SHORT					
COIL							
L803	1-406-677-11	INDUCTOR	10mH				
TRANSISTOR							
Q801	8-729-422-27	TRANSISTOR 2SD601A-QRS-TX					
Q802	8-729-216-22	TRANSISTOR 2SB709A-QRS-TX					
Q803	8-729-216-22	TRANSISTOR 2SB709A-QRS-TX					
Q804	8-729-216-22	TRANSISTOR 2SB709A-QRS-TX					
Q805	8-729-140-97	TRANSISTOR 2SB734-T-34					
Q806	8-729-422-27	TRANSISTOR 2SD601A-QRS-TX					
Q809	8-729-422-27	TRANSISTOR 2SD601A-QRS-TX					
Q810	8-729-043-95	TRANSISTOR 2SC3840K					
Q811	8-729-119-76	TRANSISTOR 2SA1309A-QRSTA					
Q812	8-729-119-76	TRANSISTOR 2SA1309A-QRSTA					
RESISTOR							
R801	1-216-089-91	RES-CHIP	47K 5% 1/10W				
R802	1-216-073-00	RES-CHIP	10K 5% 1/10W				
R803	1-216-081-00	RES-CHIP	22K 5% 1/10W				
R804	1-216-073-00	RES-CHIP	10K 5% 1/10W				
R805	1-216-065-91	RES-CHIP	4.7K 5% 1/10W				
R806	1-216-081-00	RES-CHIP	22K 5% 1/10W				
R807	1-216-061-00	RES-CHIP	3.3K 5% 1/10W				
R808	1-216-073-00	RES-CHIP	10K 5% 1/10W				
R809	1-216-081-00	RES-CHIP	22K 5% 1/10W				
R811	1-216-025-91	RES-CHIP	100 5% 1/10W				

**Note:**

The components identified by shading and mark \triangle are critical for safety. Replace only with part number specified.

Note:

Les composants identifiés par un trame et une marque \triangle sont critiques pour la sécurité. Ne les remplacer que par une pièce portant le numéro spécifié.

REF.NO.	PART NO.	DESCRIPTION	REMARK	REF.NO.	PART NO.	DESCRIPTION	REMARK
R812	1-216-061-00	RES-CHIP	3.3K 5% 1/10W	R874	1-216-037-00	RES-CHIP	330 5% 1/10W
R813	1-216-041-00	RES-CHIP	470 5% 1/10W	R875	1-216-035-00	RES-CHIP	270 5% 1/10W
R815	1-215-862-11	METAL OXIDE	68 5% 1W	R890	1-216-097-91	RES-CHIP	100K 5% 1/10W
R816	1-247-807-31	CARBON	100 5% 1/4W	TRANSFORMER			
R817	1-216-091-00	RES-CHIP	56K 5% 1/10W	T801	1-424-584-11	TRANSFORMER, DYNAMIC FOCUS	
R819	1-216-089-91	RES-CHIP	47K 5% 1/10W	CONNECTOR			
R820	1-216-683-11	METAL CHIP	22K 0.50% 1/10W	CN4001*	1-564-518-11	PLUG, CONNECTOR 3P	
R821	1-216-077-91	RES-CHIP	15K 5% 1/10W	RESISTOR			
R822	1-216-065-91	RES-CHIP	4.7K 5% 1/10W	R4001	1-216-025-91	RES-CHIP	100 5% 1/10W
R823	1-216-065-91	RES-CHIP	4.7K 5% 1/10W	R4002	1-216-045-00	RES-CHIP	680 5% 1/10W
R824	1-208-830-11	METAL CHIP	100K 0.50% 1/10W	R4003	1-216-047-91	RES-CHIP	820 5% 1/10W
R825	1-208-830-11	METAL CHIP	100K 0.50% 1/10W	R4004	1-216-057-00	RES-CHIP	2.2K 5% 1/10W
R827	1-216-065-91	RES-CHIP	4.7K 5% 1/10W	R4005	1-216-069-00	RES-CHIP	6.8K 5% 1/10W
R828	1-216-085-00	RES-CHIP	33K 5% 1/10W	SWITCH			
R829	1-208-846-11	METAL CHIP	470K 0.50% 1/10W	S4001	1-762-196-21	SWITCH, TACTILE	
R830	1-216-295-91	SHORT		S4002	1-762-196-21	SWITCH, TACTILE	
R831	1-216-049-91	RES-CHIP	1K 5% 1/10W	S4003	1-762-196-21	SWITCH, TACTILE	
R832	1-216-067-00	RES-CHIP	5.6K 5% 1/10W	S4004	1-762-196-21	SWITCH, TACTILE	
R833	1-216-687-11	METAL CHIP	33K 0.50% 1/10W	S4005	1-762-196-21	SWITCH, TACTILE	
R834	1-216-065-91	RES-CHIP	4.7K 5% 1/10W	S4006	1-762-196-21	SWITCH, TACTILE	
R835	1-216-057-00	RES-CHIP	2.2K 5% 1/10W	CAPACITOR			
R836	1-216-057-00	RES-CHIP	2.2K 5% 1/10W	C201	1-126-963-11	ELECT	4.7 μ F 20% 50V
R837	1-208-808-11	METAL CHIP	12K 0.50% 1/10W	C202	1-126-963-11	ELECT	4.7 μ F 20% 50V
R838	1-247-807-31	CARBON	100 5% 1/4W	C404	1-164-182-11	CERAMIC CHIP	0.0033 μ F 10% 50V
R839	1-216-025-91	RES-CHIP	100 5% 1/10W	C405	1-163-034-00	CERAMIC CHIP	0.033 μ F 50V
R840	1-216-093-91	RES-CHIP	68K 5% 1/10W	C406	1-163-011-11	CERAMIC CHIP	0.0015 μ F 10% 50V
R841	1-208-802-11	METAL CHIP	6.8K 0.50% 1/10W	C407	1-164-222-11	CERAMIC CHIP	0.22 μ F 25V
R842	1-208-796-11	METAL CHIP	3.9K 0.50% 1/10W	C408	1-164-222-11	CERAMIC CHIP	0.22 μ F 25V
R845	1-249-441-11	CARBON	100K 5% 1/4W	C409	1-163-011-11	CERAMIC CHIP	0.0015 μ F 10% 50V
R846	1-249-441-11	CARBON	100K 5% 1/4W	C410	1-163-034-00	CERAMIC CHIP	0.033 μ F 50V
R847	1-249-441-11	CARBON	100K 5% 1/4W	C411	1-164-182-11	CERAMIC CHIP	0.0033 μ F 10% 50V
R848	1-215-876-00	METAL OXIDE	15K 5% 1W				
R849	1-215-920-11	METAL OXIDE	3.3K 5% 3W				
R851	1-215-894-11	METAL OXIDE	2.2K 5% 2W				
R854	1-216-069-00	RES-CHIP	6.8K 5% 1/10W				
R855	1-216-089-91	RES-CHIP	47K 5% 1/10W				
R860	1-208-806-11	METAL CHIP	10K 0.50% 1/10W				
R862	1-216-057-00	RES-CHIP	2.2K 5% 1/10W				
R863	1-216-057-00	RES-CHIP	2.2K 5% 1/10W				
R864	1-216-033-00	RES-CHIP	220 5% 1/10W				
R865	1-216-097-91	RES-CHIP	100K 5% 1/10W				
R866	1-249-429-11	CARBON	10K 5% 1/4W				
R867	1-216-073-00	RES-CHIP	10K 5% 1/10W				
R868	1-216-073-00	RES-CHIP	10K 5% 1/10W				
R869	1-216-097-91	RES-CHIP	100K 5% 1/10W				
R870	1-216-057-00	RES-CHIP	2.2K 5% 1/10W				
R871	1-215-489-00	METAL	680K 1% 1/4W				
R872	1-216-121-91	RES-CHIP	1M 5% 1/10W				
R873	1-216-073-00	RES-CHIP	10K 5% 1/10W				

Note:

The components identified by shading and mark \triangle are critical for safety. Replace only with part number specified.

Note:

Les composants identifiés par un trame et une marque \triangle sont critiques pour la sécurité. Ne les remplacer que par une pièce portant le numéro spécifié.



REF.NO.	PART NO.	DESCRIPTION	REMARK	REF.NO.	PART NO.	DESCRIPTION	REMARK
C412	1-163-038-91	CERAMIC CHIP	0.1 μ F				25V
C413	1-126-963-11	ELECT	4.7 μ F			20%	50V
C414	1-126-963-11	ELECT	4.7 μ F			20%	50V
C415	1-126-963-11	ELECT	4.7 μ F			20%	50V
C416	1-126-963-11	ELECT	4.7 μ F			20%	50V
C417	1-126-963-11	ELECT	4.7 μ F			20%	50V
C418	1-163-038-91	CERAMIC CHIP	0.1 μ F				25V
C419	1-164-346-11	CERAMIC CHIP	1 μ F				16V
C422	1-126-963-11	ELECT	4.7 μ F			20%	50V
C423	1-126-963-11	ELECT	4.7 μ F			20%	50V
C446	1-126-933-11	ELECT	100 μ F			20%	16V
C447	1-126-961-11	ELECT	2.2 μ F			20%	50V
C448	1-126-961-11	ELECT	2.2 μ F			20%	50V
C450	1-126-963-11	ELECT	4.7 μ F			20%	50V
C451	1-126-963-11	ELECT	4.7 μ F			20%	50V
C475	1-163-038-91	CERAMIC CHIP	0.1 μ F				25V
CONNECTOR							
CN402	1-691-765-11	PLUG (MICRO CONNECTOR) 3P					
CN450	1-573-301-21	CONNECTOR, BOARD TO BOARD 20P					
IC							
IC404	8-759-658-01	IC NJW1130G-TE2					
CHIP CONDUCTOR							
JR403	1-216-295-91	SHORT					
JR404	1-216-295-91	SHORT					
JR407	1-216-295-91	SHORT					
JR408	1-216-295-91	SHORT					
JR420	1-216-295-91	SHORT					
JR421	1-216-295-91	SHORT					
JR422	1-216-295-91	SHORT					
JR423	1-216-295-91	SHORT					
JR426	1-216-295-91	SHORT					
JR427	1-216-295-91	SHORT					
JR428	1-216-295-91	SHORT					
JR429	1-216-295-91	SHORT					
JR452	1-216-295-91	SHORT					
JR474	1-216-295-91	SHORT					
JR477	1-216-295-91	SHORT					
COIL							
L410	1-414-271-11	INDUCTOR	47 μ H				
RESISTOR							
R219	1-216-065-91	RES-CHIP	4.7K			5%	1/10W
R220	1-216-065-91	RES-CHIP	4.7K			5%	1/10W
R403	1-216-025-91	RES-CHIP	100			5%	1/10W
R404	1-216-025-91	RES-CHIP	100			5%	1/10W
R405	1-216-025-91	RES-CHIP	100			5%	1/10W
R406	1-216-025-91	RES-CHIP	100			5%	1/10W
R407	1-216-025-91	RES-CHIP	100			5%	1/10W
R408	1-216-025-91	RES-CHIP	100			5%	1/10W
R409	1-216-025-91	RES-CHIP	100			5%	1/10W
R410	1-216-025-91	RES-CHIP	100			5%	1/10W
R450	1-216-025-91	RES-CHIP	100			5%	1/10W
R451	1-216-025-91	RES-CHIP	100			5%	1/10W
R455	1-216-025-91	RES-CHIP	100			5%	1/10W
R456	1-216-025-91	RES-CHIP	100			5%	1/10W
R477	1-216-113-00	RES-CHIP	470K			5%	1/10W
R478	1-216-113-00	RES-CHIP	470K			5%	1/10W
R479	1-216-113-00	RES-CHIP	470K			5%	1/10W
R480	1-216-113-00	RES-CHIP	470K			5%	1/10W
CAPACITOR							
C003	1-126-959-11	ELECT	0.47 μ F			20%	50V
C005	1-164-005-11	CERAMIC CHIP	0.47 μ F				25V
C005	1-164-005-11	CERAMIC CHIP (KV-27FS16 ONLY)	0.47 μ F				25V
C006	1-126-964-11	ELECT	10 μ F			20%	50V
C009	1-163-259-91	CERAMIC CHIP	220PF			5%	50V
C010	1-163-035-00	CERAMIC CHIP	0.047 μ F				50V
C011	1-163-259-91	CERAMIC CHIP	220PF			5%	50V
C012	1-163-009-11	CERAMIC CHIP	0.001 μ F			10%	50V
C015	1-163-231-11	CERAMIC CHIP	15PF			5%	50V
C016	1-163-231-11	CERAMIC CHIP	15PF			5%	50V
C017	1-126-960-11	ELECT	1 μ F			20%	50V
C019	1-163-259-91	CERAMIC CHIP	220PF			5%	50V
C020	1-163-038-91	CERAMIC CHIP	0.1 μ F				25V
C021	1-163-259-91	CERAMIC CHIP	220PF			5%	50V
C022	1-163-135-00	CERAMIC CHIP	560PF			5%	50V
C027	1-163-009-11	CERAMIC CHIP	0.001 μ F			10%	50V
C028	1-163-259-91	CERAMIC CHIP	220PF			5%	50V
C032	1-164-004-11	CERAMIC CHIP	0.1 μ F			10%	25V
C033	1-163-259-91	CERAMIC CHIP	220PF			5%	50V

- * A-1304-198-A MA (VAR) MOUNTED PC BOARD (KV-27FS16 ONLY)
- * A-1304-200-A MA (VAR) MOUNTED PC BOARD (KV-27FS12/29FS12/29FS12C)



Note:

The components identified by shading and mark \triangle are critical for safety. Replace only with part number specified.

Note:

Les composants identifiés par un trame et une marque \triangle sont critiques pour la sécurité. Ne les remplacer que par une pièce portant le numéro spécifié.

REF.NO.	PART NO.	DESCRIPTION	REMARK	REF.NO.	PART NO.	DESCRIPTION	REMARK
C034	1-163-037-11	CERAMIC CHIP	0.022 μ F 10% 50V	C316	1-163-243-11	CERAMIC CHIP	47PF 5% 50V
C037	1-164-161-11	CERAMIC CHIP	0.0022 μ F 10% 50V	C317	1-163-021-91	CERAMIC CHIP	0.01 μ F 10% 50V
C038	1-126-935-11	ELECT	470 μ F 20% 16V	C318	1-163-021-91	CERAMIC CHIP	0.01 μ F 10% 50V
C039	1-126-964-11	ELECT	10 μ F 20% 50V	C319	1-126-767-11	ELECT	1000 μ F 20% 16V
C040	1-163-229-11	CERAMIC CHIP	12PF 5% 50V	C320	1-164-005-11	CERAMIC CHIP	0.47 μ F 25V
C041	1-163-229-11	CERAMIC CHIP	12PF 5% 50V	C321	1-164-005-11	CERAMIC CHIP	0.47 μ F 25V
C042	1-163-259-91	CERAMIC CHIP	220PF 5% 50V	C322	1-164-005-11	CERAMIC CHIP	0.47 μ F 25V
C043	1-163-009-11	CERAMIC CHIP	0.001 μ F 10% 50V	C323	1-164-004-11	CERAMIC CHIP	0.1 μ F 10% 25V
C044	1-163-009-11	CERAMIC CHIP	0.001 μ F 10% 50V	C324	1-163-231-11	CERAMIC CHIP	15PF 5% 50V
C045	1-164-161-11	CERAMIC CHIP	0.0022 μ F 10% 50V	C325	1-164-005-11	CERAMIC CHIP	0.47 μ F 25V
C046	1-104-664-11	ELECT	47 μ F 20% 25V	C326	1-164-004-11	CERAMIC CHIP	0.1 μ F 10% 25V
C047	1-163-259-91	CERAMIC CHIP	220PF 5% 50V	C328	1-164-004-11	CERAMIC CHIP	0.1 μ F 10% 25V
C048	1-163-259-91	CERAMIC CHIP	220PF 5% 50V	C329	1-164-004-11	CERAMIC CHIP	0.1 μ F 10% 25V
C051	1-126-935-11	ELECT	470 μ F 20% 16V	C330	1-126-960-11	ELECT	1 μ F 20% 50V
C060	1-163-005-11	CERAMIC CHIP	470PF 10% 50V	C331	1-163-021-91	CERAMIC CHIP	0.01 μ F 10% 50V
C062	1-126-959-11	ELECT	0.47 μ F 20% 50V	C332	1-163-010-11	CERAMIC CHIP	0.0012 μ F 10% 50V
C063	1-137-194-81	MYLAR	0.47 μ F 5% 50V	C334	1-163-003-11	CERAMIC CHIP	330PF 10% 50V
C064	1-163-017-00	CERAMIC CHIP	0.0047 μ F 10% 50V	C335	1-126-963-11	ELECT	4.7 μ F 20% 50V
C070	1-163-009-11	CERAMIC CHIP	0.001 μ F 10% 50V	C336	1-104-664-11	ELECT	47 μ F 20% 25V
C071	1-163-009-11	CERAMIC CHIP	0.001 μ F 10% 50V	C338	1-164-004-11	CERAMIC CHIP	0.1 μ F 10% 25V
C076	1-163-259-91	CERAMIC CHIP	220PF 5% 50V	C339	1-126-960-11	ELECT	1 μ F 20% 50V
C077	1-163-259-91	CERAMIC CHIP	220PF 5% 50V	C340	1-126-933-11	ELECT	100 μ F 20% 16V
C091	1-163-037-11	CERAMIC CHIP	0.022 μ F 10% 50V	C341	1-163-233-11	CERAMIC CHIP	18PF 5% 50V
C093	1-163-259-91	CERAMIC CHIP	220PF 5% 50V	C345	1-163-021-91	CERAMIC CHIP	0.01 μ F 10% 50V
C097	1-163-009-11	CERAMIC CHIP	0.001 μ F 10% 50V			(KV-27FS16 ONLY)	
C099	1-126-960-11	ELECT	1 μ F 20% 50V	C346	1-163-021-91	CERAMIC CHIP	0.01 μ F 10% 50V
C151	1-126-960-11	ELECT	1 μ F 20% 50V			(KV-27FS16 ONLY)	
C153	1-163-017-00	CERAMIC CHIP	0.0047 μ F 10% 50V	C347	1-163-021-91	CERAMIC CHIP	0.01 μ F 10% 50V
C154	1-126-967-11	ELECT	47 μ F 20% 50V			(KV-27FS16 ONLY)	
C155	1-126-964-11	ELECT	10 μ F 20% 50V	C348	1-164-005-11	CERAMIC CHIP	0.47 μ F 25V
				C350	1-126-959-11	ELECT	0.47 μ F 20% 50V
C156	1-104-664-11	ELECT	47 μ F 20% 25V	C351	1-163-021-91	CERAMIC CHIP	0.01 μ F 10% 50V
						(KV-27FS16 ONLY)	
C157	1-126-968-11	ELECT	100 μ F 20% 50V	C352	1-163-021-91	CERAMIC CHIP	0.01 μ F 10% 50V
				C353	1-163-021-91	CERAMIC CHIP	0.01 μ F 10% 50V
C302	1-163-021-91	CERAMIC CHIP	0.01 μ F 10% 50V	C354	1-126-933-11	ELECT	100 μ F 20% 16V
C303	1-163-021-91	CERAMIC CHIP	0.01 μ F 10% 50V	C355	1-163-021-91	CERAMIC CHIP	0.01 μ F 10% 50V
C304	1-163-021-91	CERAMIC CHIP	0.01 μ F 10% 50V	C356	1-164-004-11	CERAMIC CHIP	0.1 μ F 10% 25V
C305	1-126-933-11	ELECT	100 μ F 20% 16V	C357	1-104-664-11	ELECT	47 μ F 20% 25V
C307	1-163-227-11	CERAMIC CHIP	10PF 0.50PF 50V	C358	1-104-664-11	ELECT	47 μ F 20% 25V
C308	1-163-021-91	CERAMIC CHIP	0.01 μ F 10% 50V	C359	1-163-021-91	CERAMIC CHIP	0.01 μ F 10% 50V
C309	1-126-933-11	ELECT	100 μ F 20% 16V	C360	1-126-959-11	ELECT	0.47 μ F 20% 50V
C310	1-126-960-11	ELECT	1 μ F 20% 50V	C361	1-163-021-91	CERAMIC CHIP	0.01 μ F 10% 50V
C311	1-163-123-00	CERAMIC CHIP	180PF 5% 50V	C362	1-104-664-11	ELECT	47 μ F 20% 25V
C313	1-163-021-91	CERAMIC CHIP	0.01 μ F 10% 50V	C363	1-163-038-91	CERAMIC CHIP	0.1 μ F 25V
C314	1-163-231-11	CERAMIC CHIP	15PF 5% 50V	C364	1-164-004-11	CERAMIC CHIP	0.1 μ F 10% 25V
C315	1-104-664-11	ELECT	47 μ F 20% 25V	C365	1-137-194-81	MYLAR	0.47 μ F 5% 50V
				C366	1-163-021-91	CERAMIC CHIP	0.01 μ F 10% 50V
				C367	1-163-005-11	CERAMIC CHIP	470PF 10% 50V
				C368	1-163-021-91	CERAMIC CHIP	0.01 μ F 10% 50V

Note:

The components identified by shading and mark \triangle are critical for safety. Replace only with part number specified.

Note:

Les composants identifiés par un trame et une marque \triangle sont critiques pour la sécurité. Ne les remplacer que par une pièce portant le numéro spécifié.



REF.NO.	PART NO.	DESCRIPTION	REMARK	REF.NO.	PART NO.	DESCRIPTION	REMARK
C369	1-163-021-91	CERAMIC CHIP	0.01 μ F 10% 50V				
C370	1-126-933-11	ELECT	100 μ F 20% 16V				
C371	1-163-243-11	CERAMIC CHIP	47PF 5% 50V				
C377	1-126-963-11	ELECT	4.7 μ F 20% 50V				
C389	1-115-185-11	CERAMIC CHIP	0.033 μ F 10% 50V				
C390	1-163-231-11	CERAMIC CHIP	15PF 5% 50V				
C391	1-126-933-11	ELECT	100 μ F 20% 16V				
C395	1-163-021-91	CERAMIC CHIP	0.01 μ F 10% 50V				
C396	1-164-004-11	CERAMIC CHIP	0.1 μ F 10% 25V				
C397	1-163-021-91	CERAMIC CHIP	0.01 μ F 10% 50V				
C398	1-126-964-11	ELECT	10 μ F 20% 50V				
C451	1-164-346-11	CERAMIC CHIP (KV-27FS16 ONLY)	1 μ F 16V				
C452	1-164-346-11	CERAMIC CHIP (KV-27FS16 ONLY)	1 μ F 16V				
C453	1-164-346-11	CERAMIC CHIP (KV-27FS16 ONLY)	1 μ F 16V				
C454	1-164-346-11	CERAMIC CHIP (KV-27FS16 ONLY)	1 μ F 16V				
CONNECTOR				FERRITE BEAD			
CN001 *	1-564-511-11	PLUG, CONNECTOR 8P		FB001	1-414-234-22	INDUCTOR CHIP	0 μ H
CN002 *	1-560-124-00	PLUG, CONNECTOR (2.5MM) 4P		FB002	1-414-234-22	INDUCTOR CHIP	0 μ H
CN003 *	1-564-512-11	PLUG, CONNECTOR 9P		FB301	1-412-911-11	FERRITE	0 μ H
CN004 *	1-564-512-11	PLUG, CONNECTOR 9P		FB302	1-412-911-11	FERRITE	0 μ H
CN005 *	1-764-333-11	PLUG, CONNECTOR 10P					
CN006 *	1-764-333-11	PLUG, CONNECTOR 10P		FILTER			
CN302 *	1-564-507-11	PLUG, CONNECTOR 4P		FL301	1-239-847-11	FILTER, LOW PASS	
CN303	1-900-805-12	CONNECTOR ASSY 9P BOARD		FL302	1-239-847-11	FILTER, LOW PASS	
CN304 *	1-564-507-11	PLUG, CONNECTOR 4P (KV-27FS16 ONLY)		FL303	1-239-847-11	FILTER, LOW PASS	
CN305	1-573-298-21	CONNECTOR, BOARD TO BOARD 20P (KV-27FS16 ONLY)		IC			
CN309 *	1-564-506-11	PLUG, CONNECTOR 3P		IC001	8-759-658-00	IC M37280MK-110SP	
CN401 *	1-564-505-11	PLUG, CONNECTOR 2P (KV-27FS16 ONLY)		IC002	8-759-663-29	IC MM1476AF(TP)	
				IC003	8-759-527-77	IC M24C16-MN6T	
				IC301 \triangle	8-752-094-98	IC CXA2154S	
				IC302	8-759-655-75	IC TC90A49P	
				CHIP CONDUCTOR			
				JR001	1-216-295-91	SHORT	
				JR002	1-216-295-91	SHORT	
				JR003	1-216-295-91	SHORT	
				JR005	1-216-295-91	SHORT	
				JR006	1-216-295-91	SHORT	
				JR007	1-216-295-91	SHORT	
				JR008	1-216-295-91	SHORT	
				JR010	1-216-295-91	SHORT	
				JR011	1-216-295-91	SHORT	
				JR090	1-216-295-91	SHORT	
				JR100	1-216-295-91	SHORT	
				JR296	1-216-295-91	SHORT	
				JR297	1-216-295-91	SHORT	
				JR298	1-216-295-91	SHORT	
				JR350	1-216-295-91	SHORT	
				JR378	1-216-295-91	SHORT	
				JR379	1-216-295-91	SHORT	
				JR399	1-216-295-91	SHORT	
				JR401	1-216-295-91	SHORT	
				COIL			
D001	8-719-976-99	DIODE UDZ-TE-17-5.1B		L002	1-414-273-11	INDUCTOR	100 μ H
D002	8-719-110-17	DIODE MTZJ-T-77-10B		L003	1-414-273-11	INDUCTOR	100 μ H
D003	8-719-073-01	DIODE MA111-TX		L040	1-408-963-11	INDUCTOR	2.7 μ H
D004	8-719-976-99	DIODE UDZ-TE-17-5.1B		L150	1-414-267-11	INDUCTOR	10 μ H
D005	8-719-109-89	DIODE MTZJ-T-77-5.6C				(KV-27FS16 ONLY)	
D006	8-719-977-22	DIODE UDZ-TE-17-9.1B		L151	1-414-273-11	INDUCTOR	100 μ H
D075	8-719-073-01	DIODE MA111-TX				(KV-27FS16 ONLY)	
D301	8-719-921-44	DIODE MTZJ-T-77-5.1C					
D303	8-719-991-33	DIODE 1SS133T-77 (KV-27FS16 ONLY)					
D305	8-719-921-44	DIODE MTZJ-T-77-5.1C					
D360	8-719-914-44	DIODE DAP202K-T-146					



Note:

The components identified by shading and mark \triangle are critical for safety. Replace only with part number specified.

Note:

Les composants identifiés par un trame et une marque \triangle sont critiques pour la sécurité. Ne les remplacer que par une pièce portant le numéro spécifié.

REF.NO.	PART NO.	DESCRIPTION	REMARK	REF.NO.	PART NO.	DESCRIPTION	REMARK
L301	1-414-267-11	INDUCTOR	10 μ H				
L302	1-414-271-11	INDUCTOR	47 μ H				
L303	1-414-856-11	INDUCTOR	10 μ H				
L304	1-414-856-11	INDUCTOR	10 μ H				
L305	1-414-267-11	INDUCTOR	10 μ H				
L308	1-414-273-11	INDUCTOR	100 μ H				
L310	1-414-273-11	INDUCTOR	100 μ H				
L350	1-414-856-11	INDUCTOR	10 μ H				
L351	1-414-856-11	INDUCTOR	10 μ H				
TRANSISTOR				RESISTOR			
Q001	8-729-216-22	TRANSISTOR 2SB709A-QRS-TX		R001	1-216-043-91	RES-CHIP	560 5% 1/10W
Q002	8-729-422-27	TRANSISTOR 2SD601A-QRS-TX		R002	1-216-041-00	RES-CHIP	470 5% 1/10W
Q003	8-729-422-27	TRANSISTOR 2SD601A-QRS-TX		R003	1-247-807-31	CARBON	100 5% 1/4W
Q004	8-729-216-22	TRANSISTOR 2SB709A-QRS-TX		R004	1-216-061-00	RES-CHIP	3.3K 5% 1/10W
Q006	8-729-216-22	TRANSISTOR 2SB709A-QRS-TX		R005	1-216-295-91	SHORT	
Q082	8-729-422-27	TRANSISTOR 2SD601A-QRS-TX		R006	1-216-025-91	RES-CHIP	100 5% 1/10W
Q151	8-729-216-22	TRANSISTOR 2SB709A-QRS-TX		R007	1-216-025-91	RES-CHIP	100 5% 1/10W
Q152	8-729-422-27	TRANSISTOR 2SD601A-QRS-TX (KV-27FS16 ONLY)		R008	1-216-049-91	RES-CHIP	1K 5% 1/10W
Q302	8-729-422-27	TRANSISTOR 2SD601A-QRS-TX		R009	1-216-121-91	RES-CHIP	1M 5% 1/10W
Q303	8-729-216-22	TRANSISTOR 2SB709A-QRS-TX		R010	1-216-033-00	RES-CHIP	220 5% 1/10W
Q305	8-729-216-22	TRANSISTOR 2SB709A-QRS-TX		R011	1-216-033-00	RES-CHIP	220 5% 1/10W
Q310	8-729-216-22	TRANSISTOR 2SB709A-QRS-TX		R012	1-216-045-00	RES-CHIP	680 5% 1/10W
Q349	8-729-422-27	TRANSISTOR 2SD601A-QRS-TX		R013	1-249-417-11	CARBON	1K 5% 1/4W
Q350	8-729-216-22	TRANSISTOR 2SB709A-QRS-TX		R014	1-216-073-00	RES-CHIP	10K 5% 1/10W
Q351	8-729-216-22	TRANSISTOR 2SB709A-QRS-TX		R015	1-216-073-00	RES-CHIP	10K 5% 1/10W
Q352	8-729-422-27	TRANSISTOR 2SD601A-QRS-TX		R016	1-216-041-00	RES-CHIP	470 5% 1/10W
Q354	8-729-216-22	TRANSISTOR 2SB709A-QRS-TX		R017	1-208-798-11	METAL CHIP	4.7K 0.50% 1/10W
Q355	8-729-216-22	TRANSISTOR 2SB709A-QRS-TX		R018	1-247-815-91	CARBON	220 5% 1/4W
Q356	8-729-422-27	TRANSISTOR 2SD601A-QRS-TX		R019	1-216-113-00	RES-CHIP	470K 5% 1/10W
Q358	8-729-422-27	TRANSISTOR 2SD601A-QRS-TX		R020	1-216-033-00	RES-CHIP	220 5% 1/10W
Q359	8-729-216-22	TRANSISTOR 2SB709A-QRS-TX		R021	1-249-429-11	CARBON	10K 5% 1/4W
Q365	8-729-422-27	TRANSISTOR 2SD601A-QRS-TX		R022	1-247-815-91	CARBON	220 5% 1/4W
Q368	8-729-422-27	TRANSISTOR 2SD601A-QRS-TX		R023	1-249-429-11	CARBON	10K 5% 1/4W
Q369	8-729-216-22	TRANSISTOR 2SB709A-QRS-TX		R024	1-247-815-91	CARBON	220 5% 1/4W
Q370	8-729-216-22	TRANSISTOR 2SB709A-QRS-TX		R025	1-249-426-11	CARBON	5.6K 5% 1/4W
Q375	8-729-422-27	TRANSISTOR 2SD601A-QRS-TX		R026	1-249-426-11	CARBON	5.6K 5% 1/4W
Q378	8-729-216-22	TRANSISTOR 2SB709A-QRS-TX (KV-27FS16 ONLY)		R027	1-249-426-11	CARBON	5.6K 5% 1/4W
Q379	8-729-119-76	TRANSISTOR 2SA1309A-QRSTA (KV-27FS16 ONLY)		R028	1-216-049-91	RES-CHIP	1K 5% 1/10W
Q380	8-729-216-22	TRANSISTOR 2SB709A-QRS-TX (KV-27FS16 ONLY)		R029	1-216-065-91	RES-CHIP	4.7K 5% 1/10W
Q387	8-729-216-22	TRANSISTOR 2SB709A-QRS-TX		R030	1-216-065-91	RES-CHIP	4.7K 5% 1/10W
Q388	8-729-216-22	TRANSISTOR 2SB709A-QRS-TX		R031	1-216-355-11	METAL OXIDE	3.3 5% 1W
Q389	8-729-216-22	TRANSISTOR 2SB709A-QRS-TX		R032	1-216-033-00	RES-CHIP	220 5% 1/10W
				R033	1-216-033-00	RES-CHIP	220 5% 1/10W
				R034	1-216-033-00	RES-CHIP	220 5% 1/10W
				R035	1-216-033-00	RES-CHIP	220 5% 1/10W
				R036	1-216-049-91	RES-CHIP	1K 5% 1/10W
				R037	1-247-815-91	CARBON	220 5% 1/4W
				R038	1-216-049-91	RES-CHIP	1K 5% 1/10W
				R039	1-216-045-00	RES-CHIP	680 5% 1/10W
				R040	1-247-815-91	CARBON	220 5% 1/4W
				R041	1-216-045-00	RES-CHIP	680 5% 1/10W
				R042	1-216-071-00	RES-CHIP	8.2K 5% 1/10W
				R043	1-249-417-11	CARBON	1K 5% 1/4W
				R044	1-216-033-00	RES-CHIP	220 5% 1/10W
				R045	1-216-065-91	RES-CHIP	4.7K 5% 1/10W

Note:

The components identified by shading and mark \triangle are critical for safety. Replace only with part number specified.

Note:

Les composants identifiés par un trame et une marque \triangle sont critiques pour la sécurité. Ne les remplacer que par une pièce portant le numéro spécifié.



REF.NO.	PART NO.	DESCRIPTION	REMARK	REF.NO.	PART NO.	DESCRIPTION	REMARK
R046	1-216-033-00	RES-CHIP	220 5% 1/10W	R256	1-216-073-00	RES-CHIP	10K 5% 1/10W
R047	1-216-065-91	RES-CHIP	4.7K 5% 1/10W	R257	1-216-049-91	RES-CHIP	1K 5% 1/10W
R048	1-216-025-91	RES-CHIP (KV-27FS16 ONLY)	100 5% 1/10W	R258	1-216-065-91	RES-CHIP	4.7K 5% 1/10W
R050	1-216-033-00	RES-CHIP	220 5% 1/10W	R259	1-249-429-11	CARBON	10K 5% 1/4W
R051	1-216-033-00	RES-CHIP	220 5% 1/10W	R260	1-247-815-91	CARBON	220 5% 1/4W
R052	1-249-417-11	CARBON	1K 5% 1/4W	R261	1-216-113-00	RES-CHIP	470K 5% 1/10W
R054	1-216-065-91	RES-CHIP	4.7K 5% 1/10W	R262	1-247-807-31	CARBON	100 5% 1/4W
R055	1-216-065-91	RES-CHIP	4.7K 5% 1/10W	R263	1-216-025-91	RES-CHIP	100 5% 1/10W
R056	1-208-798-11	METAL CHIP	4.7K 0.50% 1/10W	R264	1-216-081-00	RES-CHIP (KV-27FS16 ONLY)	22K 5% 1/10W
R057	1-216-065-91	RES-CHIP	4.7K 5% 1/10W	R266	1-216-081-00	RES-CHIP (KV-27FS16 ONLY)	22K 5% 1/10W
R058	1-216-065-91	RES-CHIP	4.7K 5% 1/10W	R267	1-216-049-91	RES-CHIP	1K 5% 1/10W
R060	1-247-815-91	CARBON	220 5% 1/4W	R268	1-216-045-00	RES-CHIP	680 5% 1/10W
R061	1-216-033-00	RES-CHIP	220 5% 1/10W	R269	1-216-049-91	RES-CHIP	1K 5% 1/10W
R064	1-216-295-91	SHORT		R270	1-216-081-00	RES-CHIP (KV-27FS16 ONLY)	22K 5% 1/10W
R069	1-247-815-91	CARBON (KV-27FS16 ONLY)	220 5% 1/4W	R271	1-216-081-00	RES-CHIP (KV-27FS16 ONLY)	22K 5% 1/10W
R070	1-216-065-91	RES-CHIP	4.7K 5% 1/10W	R272	1-216-081-00	RES-CHIP (KV-27FS16 ONLY)	22K 5% 1/10W
R071	1-216-065-91	RES-CHIP	4.7K 5% 1/10W	R273	1-216-073-00	RES-CHIP	10K 5% 1/10W
R073	1-249-425-11	CARBON	4.7K 5% 1/4W	R274	1-216-295-91	SHORT	
R074	1-216-065-91	RES-CHIP	4.7K 5% 1/10W	R275	1-216-081-00	RES-CHIP	22K 5% 1/10W
R077	1-216-097-91	RES-CHIP	100K 5% 1/10W	R276	1-216-085-00	RES-CHIP	33K 5% 1/10W
R086	1-216-045-00	RES-CHIP	680 5% 1/10W	R277	1-216-129-00	RES-CHIP	2.2M 5% 1/10W
R087	1-216-045-00	RES-CHIP	680 5% 1/10W	R278	1-216-295-91	SHORT	
R088	1-216-045-00	RES-CHIP	680 5% 1/10W	R279	1-247-807-31	CARBON	100 5% 1/4W
R091	1-216-073-00	RES-CHIP	10K 5% 1/10W	R280	1-216-069-00	RES-CHIP	6.8K 5% 1/10W
R092	1-208-798-11	METAL CHIP	4.7K 0.50% 1/10W	R281	1-208-798-11	METAL CHIP	4.7K 0.50% 1/10W
R093	1-216-065-91	RES-CHIP	4.7K 5% 1/10W	R282	1-208-790-11	METAL CHIP	2.2K 0.50% 1/10W
R094	1-216-065-91	RES-CHIP	4.7K 5% 1/10W	R283	1-216-689-11	RES-CHIP	39K 5% 1/10W
R095	1-216-065-91	RES-CHIP	4.7K 5% 1/10W	R300	1-216-295-91	SHORT	
R096	1-216-065-91	RES-CHIP	4.7K 5% 1/10W	R301	1-216-022-00	RES-CHIP	75 5% 1/10W
R097	1-249-414-11	CARBON	560 5% 1/4W	R303	1-216-073-00	RES-CHIP	10K 5% 1/10W
R099	1-216-089-91	RES-CHIP	47K 5% 1/10W	R304	1-247-807-31	CARBON	100 5% 1/4W
R150	1-216-053-00	RES-CHIP (KV-27FS16 ONLY)	1.5K 5% 1/10W	R305	1-216-295-91	SHORT	
R151	1-216-025-91	RES-CHIP (KV-27FS16 ONLY)	100 5% 1/10W	R306	1-216-025-91	RES-CHIP	100 5% 1/10W
R154	1-216-043-91	RES-CHIP (KV-27FS16 ONLY)	560 5% 1/10W	R307	1-216-071-00	RES-CHIP	8.2K 5% 1/10W
R155	1-216-043-91	RES-CHIP (KV-27FS16 ONLY)	560 5% 1/10W	R308	1-216-022-00	RES-CHIP	75 5% 1/10W
R156	1-216-085-00	RES-CHIP (KV-27FS16 ONLY)	33K 5% 1/10W	R309	1-216-022-00	RES-CHIP	75 5% 1/10W
R157	1-216-081-00	RES-CHIP (KV-27FS16 ONLY)	22K 5% 1/10W	R310	1-249-417-11	CARBON	1K 5% 1/4W
R158	1-216-025-91	RES-CHIP (KV-27FS16 ONLY)	100 5% 1/10W	R311	1-216-025-91	RES-CHIP	100 5% 1/10W
R159	1-216-025-91	RES-CHIP (KV-27FS16 ONLY)	100 5% 1/10W	R312	1-249-417-11	CARBON	1K 5% 1/4W
R251	1-216-065-91	RES-CHIP	4.7K 5% 1/10W	R313	1-216-049-91	RES-CHIP	1K 5% 1/10W
R253	1-216-049-91	RES-CHIP	1K 5% 1/10W	R314	1-216-081-00	RES-CHIP (KV-27FS16 ONLY)	22K 5% 1/10W
				R315	1-216-022-00	RES-CHIP	75 5% 1/10W
				R316	1-216-067-00	RES-CHIP	5.6K 5% 1/10W



Note:

The components identified by shading and mark △ are critical for safety. Replace only with part number specified.

Note:

Les composants identifiés par un trame et une marque △ sont critiques pour la sécurité. Ne les remplacer que par une pièce portant le numéro spécifié.

REF.NO.	PART NO.	DESCRIPTION	REMARK	REF.NO.	PART NO.	DESCRIPTION	REMARK
R317	1-247-807-31	CARBON	100 5% 1/4W	R369	1-216-033-00	RES-CHIP	220 5% 1/10W
R318	1-216-091-00	RES-CHIP	56K 5% 1/10W	R370	1-249-429-11	CARBON	10K 5% 1/4W
R319	1-216-081-00	RES-CHIP	22K 5% 1/10W	R372	1-216-043-91	RES-CHIP	560 5% 1/10W
R320	1-216-025-91	RES-CHIP	100 5% 1/10W	R373	1-216-025-91	RES-CHIP	100 5% 1/10W
R321	1-216-043-91	RES-CHIP	560 5% 1/10W	R374	1-216-025-91	RES-CHIP	100 5% 1/10W
R322	1-216-025-91	RES-CHIP	100 5% 1/10W	R375	1-216-053-00	RES-CHIP	1.5K 5% 1/10W
R323	1-216-025-91	RES-CHIP	100 5% 1/10W	R376	1-216-022-00	RES-CHIP	75 5% 1/10W
R324	1-216-065-91	RES-CHIP	4.7K 5% 1/10W	R377	1-216-057-00	RES-CHIP	2.2K 5% 1/10W
R325	1-249-417-11	CARBON	1K 5% 1/4W	R378	1-216-295-91	SHORT	
R326	1-208-806-11	METAL CHIP	10K 0.50% 1/10W	R379	1-216-049-91	RES-CHIP	1K 5% 1/10W
R327	1-216-025-91	RES-CHIP	100 5% 1/10W	R382	1-216-295-91	SHORT	
R328	1-216-025-91	RES-CHIP	100 5% 1/10W	R383	1-216-295-91	SHORT	
R329	1-216-025-91	RES-CHIP	100 5% 1/10W	R384	1-216-295-91	SHORT	
R331	1-216-049-91	RES-CHIP	1K 5% 1/10W	R386	1-216-047-91	RES-CHIP	820 5% 1/10W
R332	1-216-022-00	RES-CHIP	75 5% 1/10W	R387	1-216-025-91	RES-CHIP	100 5% 1/10W
R333	1-216-067-00	RES-CHIP	5.6K 5% 1/10W	R388	1-216-025-91	RES-CHIP	100 5% 1/10W
R334	1-216-025-91	RES-CHIP	100 5% 1/10W	R389	1-216-049-91	RES-CHIP	1K 5% 1/10W
R335	1-216-057-00	RES-CHIP	2.2K 5% 1/10W	R392	1-216-067-00	RES-CHIP	5.6K 5% 1/10W
R336	1-216-057-00	RES-CHIP	2.2K 5% 1/10W	R394	1-216-043-91	RES-CHIP	560 5% 1/10W
R337	1-216-057-00	RES-CHIP	2.2K 5% 1/10W	R395	1-216-043-91	RES-CHIP	560 5% 1/10W
R338	1-216-073-00	RES-CHIP	10K 5% 1/10W	R396	1-247-807-31	CARBON	100 5% 1/4W
R339	1-216-091-00	RES-CHIP	56K 5% 1/10W	R398	1-216-091-00	RES-CHIP	56K 5% 1/10W
R340	1-216-025-91	RES-CHIP	100 5% 1/10W	R399	1-216-109-00	RES-CHIP	330K 5% 1/10W
R341	1-216-089-91	RES-CHIP	47K 5% 1/10W	R434	1-216-065-91	RES-CHIP (KV-27FS16 ONLY)	4.7K 5% 1/10W
R342	1-216-049-91	RES-CHIP	1K 5% 1/10W	R435	1-216-065-91	RES-CHIP (KV-27FS16 ONLY)	4.7K 5% 1/10W
R343	1-216-097-91	RES-CHIP	100K 5% 1/10W				
R344	1-216-295-91	SHORT					
R345	1-216-097-91	RES-CHIP	100K 5% 1/10W				
R346	1-216-097-91	RES-CHIP	100K 5% 1/10W				
R347	1-216-025-91	RES-CHIP	100 5% 1/10W				
R349	1-216-025-91	RES-CHIP	100 5% 1/10W				
R351	1-216-041-00	RES-CHIP	470 5% 1/10W				
R352	1-247-807-31	CARBON	100 5% 1/4W				
R353	1-247-807-31	CARBON	100 5% 1/4W				
R354	1-216-025-91	RES-CHIP	100 5% 1/10W				
R355	1-216-053-00	RES-CHIP	1.5K 5% 1/10W				
R356	1-216-025-91	RES-CHIP	100 5% 1/10W				
R357	1-216-022-00	RES-CHIP	75 5% 1/10W				
R358	1-216-093-91	RES-CHIP	68K 5% 1/10W				
R359	1-216-057-00	RES-CHIP	2.2K 5% 1/10W				
R360	1-216-093-91	RES-CHIP	68K 5% 1/10W				
R361	1-216-022-00	RES-CHIP	75 5% 1/10W				
R362	1-216-035-00	RES-CHIP	270 5% 1/10W				
R363	1-216-039-00	RES-CHIP	390 5% 1/10W				
R364	1-216-025-91	RES-CHIP	100 5% 1/10W				
R365	1-216-025-91	RES-CHIP	100 5% 1/10W				
R366	1-216-053-00	RES-CHIP	1.5K 5% 1/10W				
R367	1-216-057-00	RES-CHIP	2.2K 5% 1/10W				
R368	1-216-043-91	RES-CHIP	560 5% 1/10W				

TUNER

TU150	△ 8-598-501-00	TUNER, FSS BTF-FA402 (KV-27FS16 ONLY)
-------	----------------	--

CRYSTAL

X001	1-767-487-11	VIBRATOR, CRYSTAL
X301	1-567-505-11	OSCILLATOR, CRYSTAL



* A-1190-367-A P MOUNTED PC BOARD (KV-27FS16)

CAPACITOR

C3301	1-163-031-11	CERAMIC CHIP	0.01µF	50V
C3302	1-163-031-11	CERAMIC CHIP	0.01µF	50V
C3303	1-104-664-11	ELECT	47µF	20% 16V
C3304	1-163-031-11	CERAMIC CHIP	0.01µF	50V
C3305	1-163-031-11	CERAMIC CHIP	0.01µF	50V
C3306	1-163-038-91	CERAMIC CHIP	0.1µF	25V



Note:

The components identified by shading and mark \triangle are critical for safety. Replace only with part number specified.

Note:

Les composants identifiés par un trame et une marque \triangle sont critiques pour la securite. Ne les remplacer que par une piece portant le numero specifie.

REF.NO.	PART NO.	DESCRIPTION	REMARK		REF.NO.	PART NO.	DESCRIPTION	REMARK		
C3308	1-164-005-11	CERAMIC CHIP	0.47 μ F	25V	DIODE					
C3309	1-163-034-00	CERAMIC CHIP	0.033 μ F	50V	D3301	8-719-073-01	DIODE MA111-TX			
C3310	1-164-222-11	CERAMIC CHIP	0.22 μ F	25V	D3304	8-719-422-12	DIODE UDZ-TE-17-3.9B			
C3311	1-163-233-11	CERAMIC CHIP	18PF	50V	IC					
C3314	1-163-031-11	CERAMIC CHIP	0.01 μ F	50V	IC3300	8-759-353-00	IC NJM2534M(TE2)			
C3315	1-163-031-11	CERAMIC CHIP	0.01 μ F	50V	IC3301	8-759-660-74	IC M65664FP-DS60S			
C3316	1-163-133-00	CERAMIC CHIP	470PF	50V	IC3302	8-759-458-18	IC TDA8501T			
C3317	1-163-133-00	CERAMIC CHIP	470PF	50V	COIL					
C3319	1-163-133-00	CERAMIC CHIP	470PF	50V	L3300	1-414-267-11	INDUCTOR	10 μ H		
C3320	1-164-005-11	CERAMIC CHIP	0.47 μ F	25V	L3301	1-410-682-31	INDUCTOR	470 μ H		
C3321	1-163-009-11	CERAMIC CHIP	0.001 μ F	10%	L3302	1-414-267-11	INDUCTOR	10 μ H		
C3323	1-104-664-11	ELECT	47 μ F	20%	L3303	1-414-267-11	INDUCTOR	10 μ H		
C3324	1-163-031-11	CERAMIC CHIP	0.01 μ F	50V	L3304	1-414-267-11	INDUCTOR	10 μ H		
C3325	1-163-031-11	CERAMIC CHIP	0.01 μ F	50V	TRANSISTOR					
C3326	1-104-664-11	ELECT	47 μ F	20%	Q3300	8-729-422-27	TRANSISTOR 2SD601A-QRS-TX			
C3327	1-104-664-11	ELECT	47 μ F	20%	Q3301	8-729-422-27	TRANSISTOR 2SD601A-QRS-TX			
C3328	1-104-664-11	ELECT	47 μ F	20%	Q3302	8-729-422-27	TRANSISTOR 2SD601A-QRS-TX			
C3330	1-126-964-11	ELECT	10 μ F	20%	Q3304	8-729-216-22	TRANSISTOR 2SB709A-QRS-TX			
C3331	1-163-009-11	CERAMIC CHIP	0.001 μ F	10%	Q3305	8-729-216-22	TRANSISTOR 2SB709A-QRS-TX			
C3332	1-164-346-11	CERAMIC CHIP	1 μ F	16V	Q3306	8-729-216-22	TRANSISTOR 2SB709A-QRS-TX			
C3333	1-164-346-11	CERAMIC CHIP	1 μ F	16V	Q3308	8-729-216-22	TRANSISTOR 2SB709A-QRS-TX			
C3334	1-164-005-11	CERAMIC CHIP	0.47 μ F	25V	Q3309	8-729-422-27	TRANSISTOR 2SD601A-QRS-TX			
C3335	1-163-009-11	CERAMIC CHIP	0.001 μ F	10%	Q3311	8-729-111-55	TRANSISTOR 2SD1292			
C3336	1-163-031-11	CERAMIC CHIP	0.01 μ F	50V	Q3312	8-729-216-22	TRANSISTOR 2SB709A-QRS-TX			
C3339	1-163-005-11	CERAMIC CHIP	470PF	10%	Q3313	8-729-422-27	TRANSISTOR 2SD601A-QRS-TX			
C3340	1-126-967-11	ELECT	47 μ F	20%	Q3314	8-729-422-27	TRANSISTOR 2SD601A-QRS-TX			
C3341	1-164-222-11	CERAMIC CHIP	0.22 μ F	25V	Q3315	8-729-216-22	TRANSISTOR 2SB709A-QRS-TX			
C3342	1-163-037-11	CERAMIC CHIP	0.022 μ F	10%	Q3316	8-729-216-22	TRANSISTOR 2SB709A-QRS-TX			
C3343	1-126-967-11	ELECT	47 μ F	20%	Q3317	8-729-422-27	TRANSISTOR 2SD601A-QRS-TX			
C3344	1-164-222-11	CERAMIC CHIP	0.22 μ F	25V	Q3318	8-729-422-27	TRANSISTOR 2SD601A-QRS-TX			
C3345	1-164-346-11	CERAMIC CHIP	1 μ F	16V	Q3319	8-729-422-27	TRANSISTOR 2SD601A-QRS-TX			
C3346	1-164-346-11	CERAMIC CHIP	1 μ F	16V	Q3320	8-729-422-27	TRANSISTOR 2SD601A-QRS-TX			
C3347	1-164-346-11	CERAMIC CHIP	1 μ F	16V	Q3321	8-729-216-22	TRANSISTOR 2SB709A-QRS-TX			
C3349	1-164-005-11	CERAMIC CHIP	0.47 μ F	25V	Q3323	8-729-422-27	TRANSISTOR 2SD601A-QRS-TX			
C3350	1-163-233-11	CERAMIC CHIP	18PF	50V	RESISTOR					
C3351	1-163-113-00	CERAMIC CHIP	68PF	50V	R3300	1-216-041-00	RES-CHIP	470	5%	1/10W
C3352	1-164-222-11	CERAMIC CHIP	0.22 μ F	25V	R3303	1-216-073-00	RES-CHIP	10K	5%	1/10W
C3353	1-126-967-11	ELECT	47 μ F	20%	R3304	1-216-133-00	RES-CHIP	3.3M	5%	1/10W
C3354	1-163-037-11	CERAMIC CHIP	0.022 μ F	10%	R3305	1-216-037-00	RES-CHIP	330	5%	1/10W
C3355	1-164-346-11	CERAMIC CHIP	1 μ F	16V	R3308	1-216-085-00	RES-CHIP	33K	5%	1/10W
C3356	1-164-346-11	CERAMIC CHIP	1 μ F	16V	R3309	1-216-025-91	RES-CHIP	100	5%	1/10W
C3357	1-164-346-11	CERAMIC CHIP	1 μ F	16V	R3310	1-216-025-91	RES-CHIP	100	5%	1/10W
CONNECTOR										
CN3300	1-573-301-21	CONNECTOR, BOARD TO BOARD 20P								



Note:

The components identified by shading and mark \triangle are critical for safety. Replace only with part number specified.

Note:

Les composants identifiés par un trame et une marque \triangle sont critiques pour la sécurité. Ne les remplacer que par une pièce portant le numéro spécifié.

REF.NO.	PART NO.	DESCRIPTION	REMARK	REF.NO.	PART NO.	DESCRIPTION	REMARK
R3311	1-216-037-00	RES-CHIP	330 5% 1/10W	R3376	1-216-025-91	RES-CHIP	100 5% 1/10W
R3312	1-216-043-91	RES-CHIP	560 5% 1/10W	R3377	1-216-041-00	RES-CHIP	470 5% 1/10W
R3313	1-216-035-00	RES-CHIP	270 5% 1/10W	R3378	1-216-049-91	RES-CHIP	1K 5% 1/10W
R3316	1-216-295-91	SHORT		R3379	1-216-049-91	RES-CHIP	1K 5% 1/10W
R3317	1-216-295-91	SHORT		R3380	1-216-043-91	RES-CHIP	560 5% 1/10W
R3318	1-216-061-00	RES-CHIP	3.3K 5% 1/10W	R3381	1-216-041-00	RES-CHIP	470 5% 1/10W
R3319	1-216-295-91	SHORT		R3382	1-216-043-91	RES-CHIP	560 5% 1/10W
R3320	1-216-073-00	RES-CHIP	10K 5% 1/10W	R3383	1-216-041-00	RES-CHIP	470 5% 1/10W
R3321	1-216-049-91	RES-CHIP	1K 5% 1/10W	R3384	1-216-045-00	RES-CHIP	680 5% 1/10W
R3322	1-216-091-00	RES-CHIP	56K 5% 1/10W	R3385	1-216-043-91	RES-CHIP	560 5% 1/10W
R3323	1-216-049-91	RES-CHIP	1K 5% 1/10W	R3386	1-216-041-00	RES-CHIP	470 5% 1/10W
R3324	1-216-033-00	RES-CHIP	220 5% 1/10W	R3387	1-216-049-91	RES-CHIP	1K 5% 1/10W
R3325	1-216-057-00	RES-CHIP	2.2K 5% 1/10W	R3388	1-216-049-91	RES-CHIP	1K 5% 1/10W
R3328	1-216-295-91	SHORT		R3392	1-208-834-11	METAL CHIP	150K 0.5% 1/10W
R3329	1-216-033-00	RES-CHIP	220 5% 1/10W	R3393	1-216-295-91	SHORT	
R3333	1-216-049-91	RES-CHIP	1K 5% 1/10W	R3395	1-216-689-11	RES-CHIP	39K 5% 1/10W
R3334	1-216-049-91	RES-CHIP	1K 5% 1/10W	R3396	1-216-081-00	RES-CHIP	22K 5% 1/10W
R3335	1-216-049-91	RES-CHIP	1K 5% 1/10W	R3397	1-216-025-91	RES-CHIP	100 5% 1/10W
R3336	1-216-295-91	SHORT		R3398	1-216-047-91	RES-CHIP	820 5% 1/10W
R3338	1-216-295-91	SHORT		R3399	1-216-045-00	RES-CHIP	680 5% 1/10W
R3340	1-216-295-91	SHORT		R3400	1-216-089-91	RES-CHIP	47K 5% 1/10W
R3341	1-216-057-00	RES-CHIP	2.2K 5% 1/10W	R3401	1-216-089-91	RES-CHIP	47K 5% 1/10W
R3342	1-216-295-91	SHORT		R3402	1-216-081-00	RES-CHIP	22K 5% 1/10W
R3343	1-216-065-91	RES-CHIP	4.7K 5% 1/10W	R3403	1-216-089-91	RES-CHIP	47K 5% 1/10W
R3344	1-216-073-00	RES-CHIP	10K 5% 1/10W	R3404	1-216-081-00	RES-CHIP	22K 5% 1/10W
R3345	1-216-073-00	RES-CHIP	10K 5% 1/10W	R3405	1-216-089-91	RES-CHIP	47K 5% 1/10W
R3346	1-216-045-00	RES-CHIP	680 5% 1/10W				
R3347	1-216-049-91	RES-CHIP	1K 5% 1/10W				
R3349	1-215-857-11	METAL OXIDE	10 5% 1W				
R3350	1-216-049-91	RES-CHIP	1K 5% 1/10W				
R3351	1-216-041-00	RES-CHIP	470 5% 1/10W				
R3355	1-216-049-91	RES-CHIP	1K 5% 1/10W				
R3356	1-216-113-00	RES-CHIP	470K 5% 1/10W				
R3357	1-216-041-00	RES-CHIP	470 5% 1/10W				
R3358	1-216-689-11	RES-CHIP	39K 5% 1/10W				
R3359	1-216-113-00	RES-CHIP	470K 5% 1/10W				
R3360	1-216-051-00	RES-CHIP	1.2K 5% 1/10W				
R3361	1-216-045-00	RES-CHIP	680 5% 1/10W				
R3365	1-216-073-00	RES-CHIP	10K 5% 1/10W				
R3366	1-216-049-91	RES-CHIP	1K 5% 1/10W				
R3367	1-216-073-00	RES-CHIP	10K 5% 1/10W				
R3368	1-216-049-91	RES-CHIP	1K 5% 1/10W				
R3369	1-216-049-91	RES-CHIP	1K 5% 1/10W				
R3370	1-216-049-91	RES-CHIP	1K 5% 1/10W				
R3371	1-216-049-91	RES-CHIP	1K 5% 1/10W				
R3372	1-216-049-91	RES-CHIP	1K 5% 1/10W				
R3373	1-216-049-91	RES-CHIP	1K 5% 1/10W				
R3374	1-216-025-91	RES-CHIP	100 5% 1/10W				
R3375	1-216-025-91	RES-CHIP	100 5% 1/10W				

CRYSTAL

X3300	1-567-505-11	OSCILLATOR, CRYSTAL
X3301	1-781-377-11	VIBRATOR, CRYSTAL



* A-1342-550-A VA (VAR) MOUNTED PC BOARD

4-382-854-11 SCREW (M3X10), P, SW (+)

CAPACITOR

C805	1-129-763-00	FILM	0.033 μ F	5%	200V
C811	1-129-765-00	FILM	0.047 μ F	5%	200V
C901	1-107-667-11	ELECT	2.2 μ F	20%	160V
C902	1-130-491-00	MYLAR	0.047 μ F	5%	50V
C903	1-126-925-11	ELECT	470 μ F	20%	10V
C904	1-130-471-00	MYLAR	0.001 μ F	5%	50V
C905	1-106-383-00	MYLAR	0.047 μ F	10%	200V
C906	1-130-471-00	MYLAR	0.001 μ F	5%	50V
C907	1-107-638-11	ELECT	33 μ F	20%	160V

Note:

The components identified by shading and mark \triangle are critical for safety. Replace only with part number specified.

Note:

Les composants identifiés par un trame et une marque \triangle sont critiques pour la sécurité. Ne les remplacer que par une pièce portant le numéro spécifié.



REF.NO.	PART NO.	DESCRIPTION	REMARK			REF.NO.	PART NO.	DESCRIPTION	REMARK		
C908	1-126-925-11	ELECT	470 μ F	20%	10V	R906	1-249-432-11	CARBON	18K	5%	1/4W
C909	1-161-830-00	CERAMIC	0.0047 μ F		500V	R907	1-249-386-11	CARBON	2.7	5%	1/4W
C910	1-104-999-11	MYLAR	0.1 μ F	10%	200V	R908	1-249-414-11	CARBON	560	5%	1/4W
C911	1-104-665-11	ELECT	100 μ F	20%	10V	R909	1-260-312-11	CARBON	47	5%	1/2W
C912	1-126-941-11	ELECT	470 μ F	20%	25V	R910	1-216-476-11	METAL OXIDE	180	5%	3W
C913	1-102-074-00	CERAMIC	0.001 μ F	10%	50V	R911	1-249-403-11	CARBON	68	5%	1/4W
C914	1-130-491-00	MYLAR	0.047 μ F	5%	50V	R912	1-247-815-91	CARBON	220	5%	1/4W
CONNECTOR						R913	1-249-403-11	CARBON	68	5%	1/4W
CN901 *	1-564-508-11	PLUG, CONNECTOR 5P				R914	1-249-410-11	CARBON	270	5%	1/4W
CN902 *	1-770-723-11	CONNECTOR, BOARD TO BOARD 8P				R915	1-249-417-11	CARBON	1K	5%	1/4W
CN904 *	1-564-507-11	PLUG, CONNECTOR 4P				R916	1-249-417-11	CARBON	1K	5%	1/4W
DIODE						R917	1-249-417-11	CARBON	1K	5%	1/4W
D804	8-719-302-43	DIODE RGP10GPKG23				R918	1-247-807-31	CARBON	100	5%	1/4W
D805	8-719-991-33	DIODE 1SS133T-77				R919	1-247-807-31	CARBON	100	5%	1/4W
D806	8-719-991-33	DIODE 1SS133T-77				R920	1-249-416-11	CARBON	820	5%	1/4W
D807	8-719-210-21	DIODE ERA82-004TP5				R921	1-249-429-11	CARBON	10K	5%	1/4W
D901	8-719-110-88	DIODE MTZJ-T-77-39				R922	1-249-397-11	CARBON	22	5%	1/4W
D902	8-719-110-88	DIODE MTZJ-T-77-39				R923	1-249-401-11	CARBON	47	5%	1/4W
D903	8-719-991-33	DIODE 1SS133T-77				<hr/>					
COIL						ACCESSORIES AND PACKAGING					
L801	1-406-989-21	INDUCTOR	10mH			*	4-392-859-01	BAG, PROTECTION			
L802	1-459-111-00	INDUCTOR	10mH			*	4-074-568-01	CARTON, INDIVIDUAL (KV-27FS12/27FS16 ONLY)			
L901	1-412-528-11	INDUCTOR	18 μ H			*	4-075-478-01	CARTON, INDIVIDUAL (KV-29FS12 ONLY)			
TRANSISTOR						*	4-074-565-01	CUSHION ASSY, REAR (UPPER)			
Q807	8-729-931-45	TRANSISTOR IRF614				*	4-074-566-01	CUSHION ASSY, FRONT (UPPER)			
Q808	8-729-140-97	TRANSISTOR 2SB734-T-34				*	4-074-567-01	CUSHION ASSY, LOWER			
Q901	8-729-017-06	TRANSISTOR 2SC4793					4-075-499-21	MANUAL, INSTRUCTION (KV-27FS12/27FS16 ONLY)			
Q902	8-729-017-05	TRANSISTOR 2SA1837					4-075-499-41	MANUAL, INSTRUCTION (KV-29FS12/29FS12C ONLY)			
Q903	8-729-423-33	TRANSISTOR 2SC3311A-QRSTA				<hr/>					
Q904	8-729-423-33	TRANSISTOR 2SC3311A-QRSTA				REMOTE COMMANDER					
Q905	8-729-119-76	TRANSISTOR 2SA1309A-QRSTA				1-418-387-11	REMOTE COMMANDER (RM-Y168) (ALL EXCEPT KV-27FS16)				
Q906	8-729-423-33	TRANSISTOR 2SC3311A-QRSTA				4-978-977-01	BATTERY COVER FOR RM-Y168				
RESISTOR						1-418-384-11	REMOTE COMMANDER (RM-Y169) (KV-27FS16 ONLY)				
R818	1-216-025-91	RES-CHIP	100	5%	1/10W	4-978-977-01	BATTERY COVER FOR RM-Y169				
R826	1-249-421-11	CARBON	2.2K	5%	1/4W						
R876	1-216-049-91	RES-CHIP	1K	5%	1/10W						
R901	1-249-401-11	CARBON	47	5%	1/4W						
R902	1-249-386-11	CARBON	2.7	5%	1/4W						
R903	1-249-414-11	CARBON	560	5%	1/4W						
R904	1-249-432-11	CARBON	18K	5%	1/4W						
R905	1-249-417-11	CARBON	1K	5%	1/4W						

NOTES:

A series of horizontal lines for taking notes, starting below the 'NOTES:' label and extending across the width of the page.

<i>MODEL</i>	<i>COMMANDER</i>	<i>DEST</i>	<i>CHASSIS NO.</i>
KV-27FS12	RM-Y168	US	SCC-S40D-A
KV-27FS12	RM-Y168	CND	SCC-S41D-A
KV-27FS16	RM-Y169	US	SCC-S40E-A
KV-29FS12	RM-Y168	E	SCC-S38K-A
KV-29FS12C	RM-Y168	E	SCC-S38L-A

CORRECTION-1

Subject: New Block Diagrams

**Correct the service manual as shown below.
File this correction with the service manual.**

**Section 6: Block Diagrams (Page 31-34)
Size of Block Diagrams increased and replaced.**

SECTION 6
DIAGRAMS

6.1 BLOCK DIAGRAM (1/2)

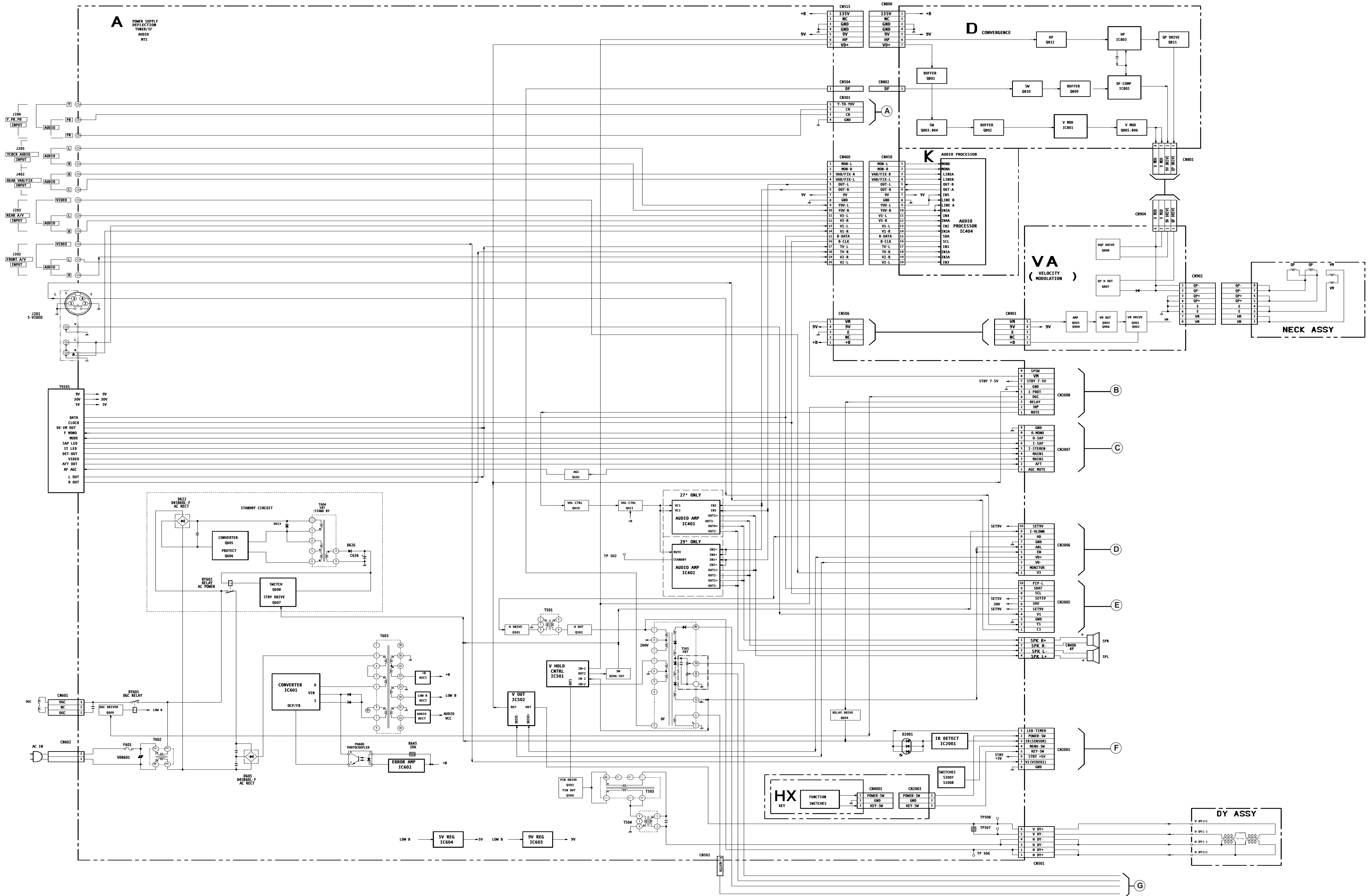

6.1 BLOCK DIAGRAM (2/2)

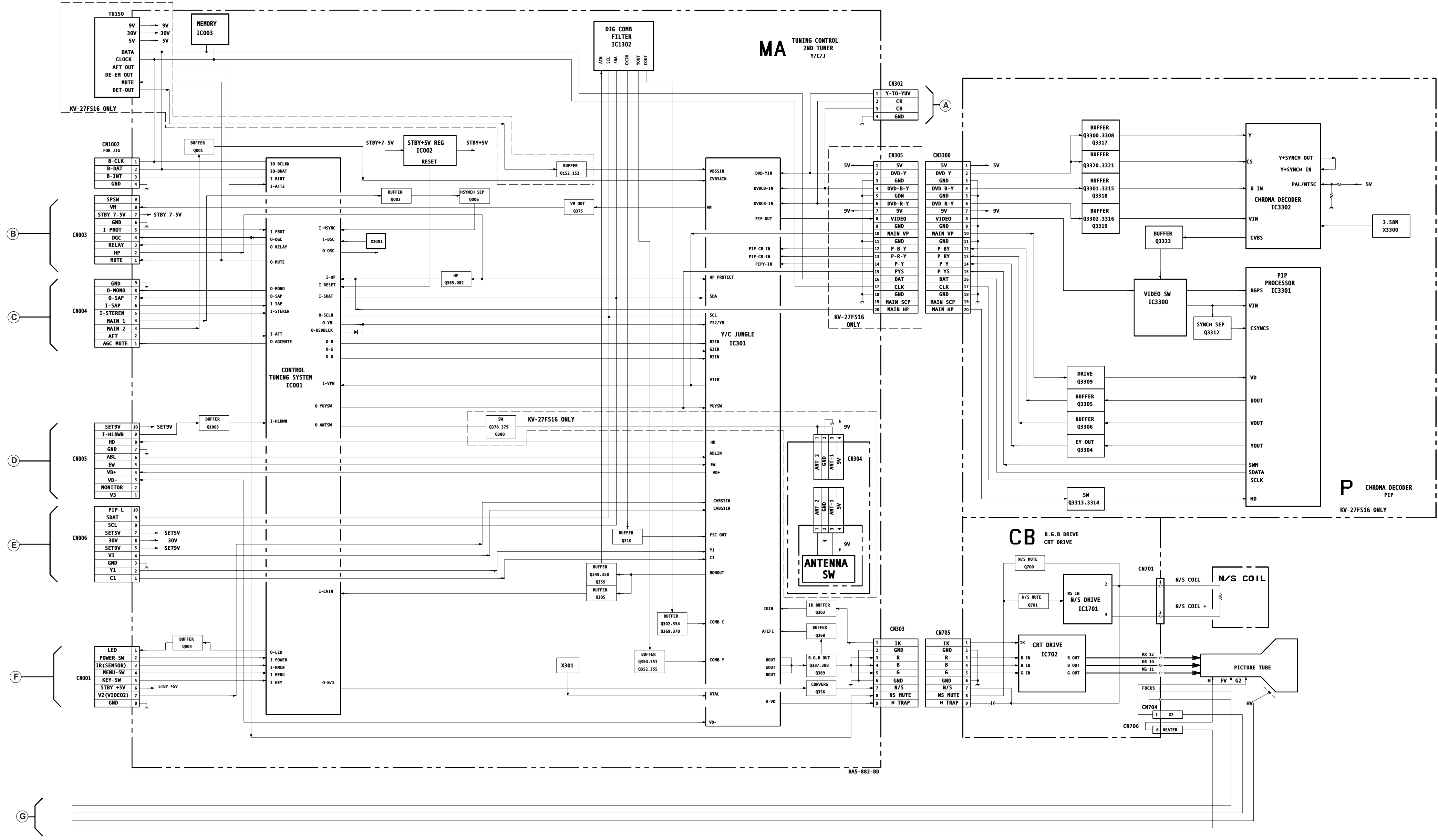

SERVICE MANUAL

BA-5 CHASSIS

<u>MODEL NAME</u>	<u>REMOTE COMMANDER</u>	<u>DESTINATION</u>	<u>CHASSIS NO.</u>
KV-27FS12	RM-Y168	US	SCC-S40D-A
KV-27FS12	RM-Y168	CND	SCC-S41D-A
KV-27FS16	RM-Y169	US	SCC-S40E-A
KV-29FS12	RM-Y168	E	SCC-S38K-A
KV-29FS12C	RM-Y168	E	SCC-S38L-A

CORRECTION - 2







Subject: Tuner P/N Change

Correct the service manual as shown below.
File this correction with the service manual.

Section 7: Exploded Views (Page 59)

7-2. CHASSIS (KV-27FS12/27FS16 ONLY)

 :Modified Item

Incorrect				Correct			
<u>REF. NO.</u>	<u>PART NO.</u>	<u>DESCRIPTION</u>	<u>REMARK</u>	<u>REF. NO.</u>	<u>PART NO.</u>	<u>DESCRIPTION</u>	<u>REMARK</u>
38 	8-598-431-30	TUNER, FSS BTF-WA411		38 	8-598-542-20	TUNER, FSS BTF-WA412	
<p>Section 8: Electrical Parts List (Page 66)</p>				<p></p>			
TU101 	8-598-431-30	TUNER, FSS BTF-WA411		TU101 	8-598-542-20	TUNER, FSS BTF-WA412	
<p></p>				<p></p>			

TRINITRON® COLOR TV
SONY®

Sony Corporation
Sony Technology Center
Technical Services
Service Promotion Department

English
2001HJ74325-1
Printed in USA
© 2001.8

HISTORY INFORMATION FOR THE FOLLOWING MANUAL:

SERVICE MANUAL

BA-5 CHASSIS

<u>MODEL NAME</u>	<u>REMOTE COMMANDER</u>	<u>DESTINATION</u>	<u>CHASSIS NO.</u>
KV-27FS12	RM-Y168	US	SCC-S40D-A
KV-27FS12	RM-Y168	CND	SCC-S41D-A
KV-27FS16	RM-Y169	US	SCC-S40E-A
KV-29FS12	RM-Y168	E	SCC-S38K-A
KV-29FS12C	RM-Y168	E	SCC-S38L-A

ORIGINAL MANUAL ISSUE DATE: 5/2001

ALL REVISIONS AND UPDATES TO THE ORIGINAL MANUAL ARE APPENDED TO THE END OF THE PDF FILE.

<u>REVISION DATE</u>	<u>REVISION TYPE</u>	<u>SUBJECT</u>
5/2001	No revisions or updates are applicable at this time.	
6/2001	CORRECTION-1	New Block Diagram
8/2001	CORRECTION-2	Tuner P/N Change

TRINITRON® COLOR TV
SONY®